



YAMAHA

PARTS CATALOGUE

YZ490T (2HJ)

172HJ-700E1

A2

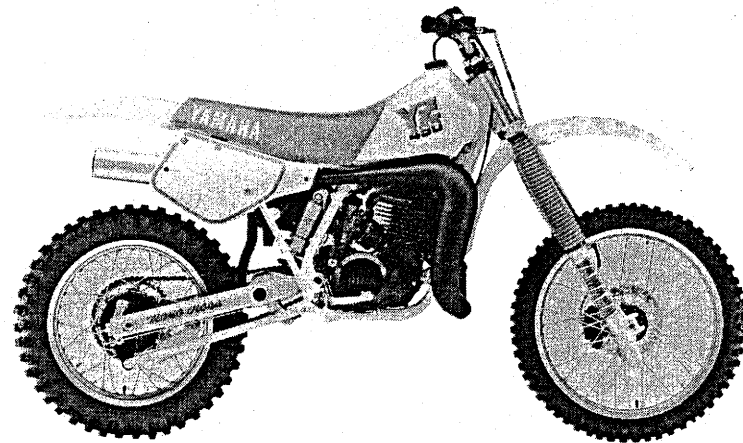

A3

FOREWORD

This Parts Catalogue is related to the parts in use for the Yamaha YZ490T (2HJ).
When you are ordering replacement parts for the YZ490T (2HJ), refer to this Parts Catalogue and quote both part numbers and part names correctly.

1. Modifications or additions which have been made after issue of the Parts Catalogue will be announced in the Yamaha Parts News.

It is advisable that according to the Yamaha Parts News you make necessary corrections to the Parts Catalogue on hand to keep it up-to-date.

2. Abbreviations

The following abbreviations are used in this Parts Catalogue.

- U.R. Use size (thickness) and/or number as required.
- U.N. Use as many as you need.
- A.P. Alternate Parts
- L.M. Local Made
- F≠ Frame No. (Applicable machine No.)

3. The parts marked with (+) in the parts number column of this Catalogue are not supplied with by Yamaha, those have to be found locally.

4. Parts, which are to be supplied in the form of assemblies, are listed with an indention of one letter's space, and a dot (.) is put against the name of each part.

EXAMPLE CARBURETOR ASS'Y
 . JET, pilot
 . NOZZLE, main

5. Indication of No. of constituent parts for assembly

The numeral appearing to the right of each constituent part under the description indicates the quantity of such parts for each individual assembly unit.

EXAMPLE

Part No.	Description	Q'ty	Remarks
2F5-83310-60	FRONT FLASHER LIGHT ASS'Y	2	
115-83311-60	. BULB (6V-18W)	1	
1M1-83309-60	. REFLECTOR	1	

6. Initial Serial No. and Color Code

(A) Frame Serial No.	2HJ-000101 and following
(B) Engine Serial No.	2HJ-000101 and following

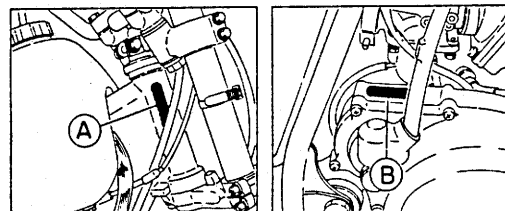

Color Code	Color Name	Abbreviate
36	CLEAN WHITE	W

7. Applicable colors of graphics are represented in the "Remarks" column by the letter(s) appropriately picked out of the full word(s) showing such colors.

EXAMPLE

Part No.	Description	Q'ty	Remarks
2N4-24110-00-X5	FUEL TANK COMP.	1	MAXIM RED
3J1-24240-10	. GRAPHIC, fuel tank set	1	for MXR

CONTENTS

ENGINE

Cylinder	B2
Crankshaft. Piston	B3
Intake	B4 ~ B5
Carburetor	B6 ~ B7
Exhaust	B8
Crankcase	B9
Crankcase Cover 1	B10
Starter	B11
Clutch	B12
Transmission	B13 ~ B14
Shift Cam. Fork	B15
Shift Shaft	C2

CHASSIS

Frame	C3
Fender	C4
Side Cover	C5
Rear Arm	C6 ~ C7
Rear Suspension	C8
Steering	C9
Front Fork	C10 ~ C12
Fuel Tank	C13 ~ C14
Seat	C15
Front Wheel	D2
Front Brake Caliper	D3
Rear Wheel	D4 ~ D5
Steering Handle. Cable	D6
Front Master Cylinder	D7
Stand. Footrest	D8

Generator	D9
Handle Switch. Lever	D10
Electrical 1	D11

ALTERNATE PARTS

Alternate 1 (Chassis)	D12
-----------------------------	-----

REPAIR KIT

Repair Kit	D13 ~ D14
------------------	-----------

INDEX

Numerical Index	M1 ~ M3
-----------------------	---------

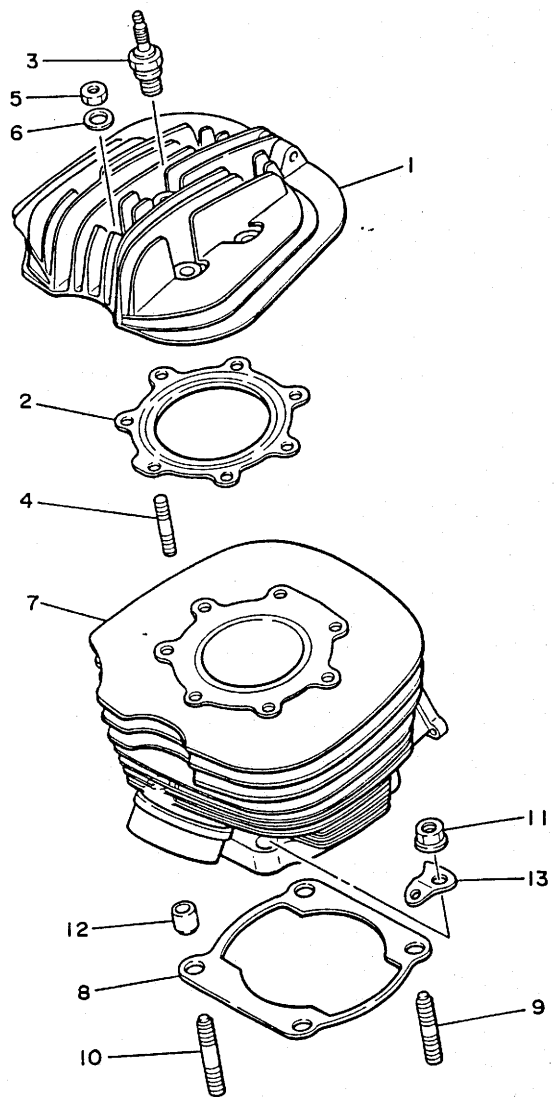
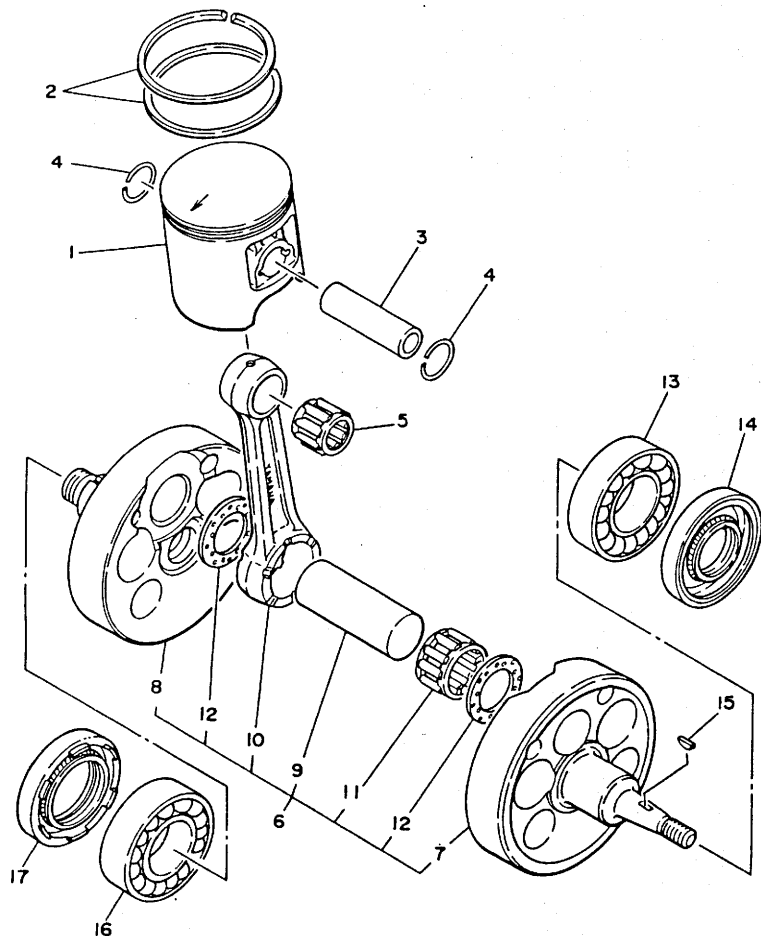

FIG. 1 CYLINDER

REF. NO.	PART NO.	DESCRIPTION	Q'TY	REMARKS
1	40T-11111-00	HEAD, cylinder 1	1	
2	40T-11181-00	GASKET, cylinder head 1	1	
3	*	PLUG, spark (CHAMPION N-86)	1	UR LM
	*	PLUG, spark (CHAMPION QN86)	1	UR LM FOR S.AFRICA
4	90116-08394	BOLT, stud	7	
5	95301-08600	NUT	7	
6	90201-08649	WASHER, plate	7	
7	2HJ-11311-00	CYLINDER 1	1	
8	1LV-11351-00	GASKET, cylinder	1	
9	90116-12315	BOLT, stud	2	
10	90116-12316	BOLT, stud	2	
11	95701-12100	NUT, flange	4	
12	91810-17016	PIN, dowel	2	
13	40T-14619-01	HOOK, spring	1	



40T100-4010



5X6100-2021

FIG. 2 CRANKSHAFT. PISTON

REF. NO.	PART NO.	DESCRIPTION	Q'TY	REMARKS
1	40T-11631-00-93	PISTON (STD)	1	UR
	40T-11631-00-94	PISTON (STD)	1	UR
	40T-11635-00	PISTON (0.25MM O/S)	1	AP
	40T-11636-00	PISTON (0.50MM O/S)	1	AP
	40T-11637-00	PISTON (0.75MM O/S)	1	AP
	40T-11638-00	PISTON (1.00MM O/S)	1	AP
2	5X6-11601-00	PISTON RING SET (STD)	1	
	5X6-11601-10	PISTON RING SET (1ST O/S)	1	AP
	5X6-11601-20	PISTON RING SET (2ND O/S)	1	AP
	5X6-11601-30	PISTON RING SET (3RD O/S)	1	AP
	5X6-11601-40	PISTON RING SET (4TH O/S)	1	AP
3	275-11633-00	PIN, piston	1	
4	93450-19052	CIRCLIP	2	
5	93310-418E9	BEARING, cylindrical	1	
6	40T-11400-00	CRANKSHAFT ASSY	1	
7	3R5-11412-00	.CRANK 1	1	
8	3R5-11422-00	.CRANK 2	1	
9	3R8-11681-00	.PIN, crank 1	1	
10	3R5-11651-00	.ROD, connecting	1	
11	93310-425N4	.BEARING, cylindrical	1	
12	90209-25085	.WASHER	2	
13	93306-30615	BEARING (B6306)	1	
14	93103-30150	OIL SEAL	1	
15	90280-03045	KEY, woodruff	1	
16	93306-30615	BEARING (B6306)	1	
17	93103-40091	OIL SEAL	1	

FIG. 3 INTAKE

REF. NO.	PART NO.	DESCRIPTION	Q'TY	REMARKS
1	56A-13610-01	REED VALVE ASSY	1	
2	56A-13613-00	.REED, valve	2	
3	56A-13616-00	.STOPPER, reed valve	2	
4	98580-03008	.SCREW, pan head	8	
5	92990-03100	.WASHER, spring	8	
6	39X-13621-00	GASKET, valve seat	1	
7	2HJ-13565-00	JOINT, carburetor	1	
8	40T-13581-00	CHAMBER, air	1	
9	4V3-1441K-00	EMBLEM	1	
10	26A-13575-00	BAND	1	
11	1LV-13584-00	PIPE, intake manifold	1	
12	90467-23059	CLIP	2	
13	90460-56257	CLAMP, hose	1	
14	91316-06020	BOLT	6	
15	90460-74254	CLAMP, hose	1	
16	2HJ-14453-00	JOINT, air cleaner 1	1	
17	56A-14459-00	HOLDER, guide	1	
18	39X-14462-00	SEAL	2	
19	39K-14457-00	SEAL	1	
20	90504-03033	SPRING, compression	1	
21	1LU-W1441-00	AIR CLEANER CASE COMP.	1	
22	1LU-14477-00	PLATE	1	
23	95601-05100	NUT, u	6	
24	2HH-14451-00	ELEMENT, air cleaner	1	
25	2HH-14458-00	GUIDE	1	
26	2HH-14468-00	PLATE, element fitting	1	
27	90122-06025	BOLT, wing	1	
28	90119-06081	BOLT, with washer	2	

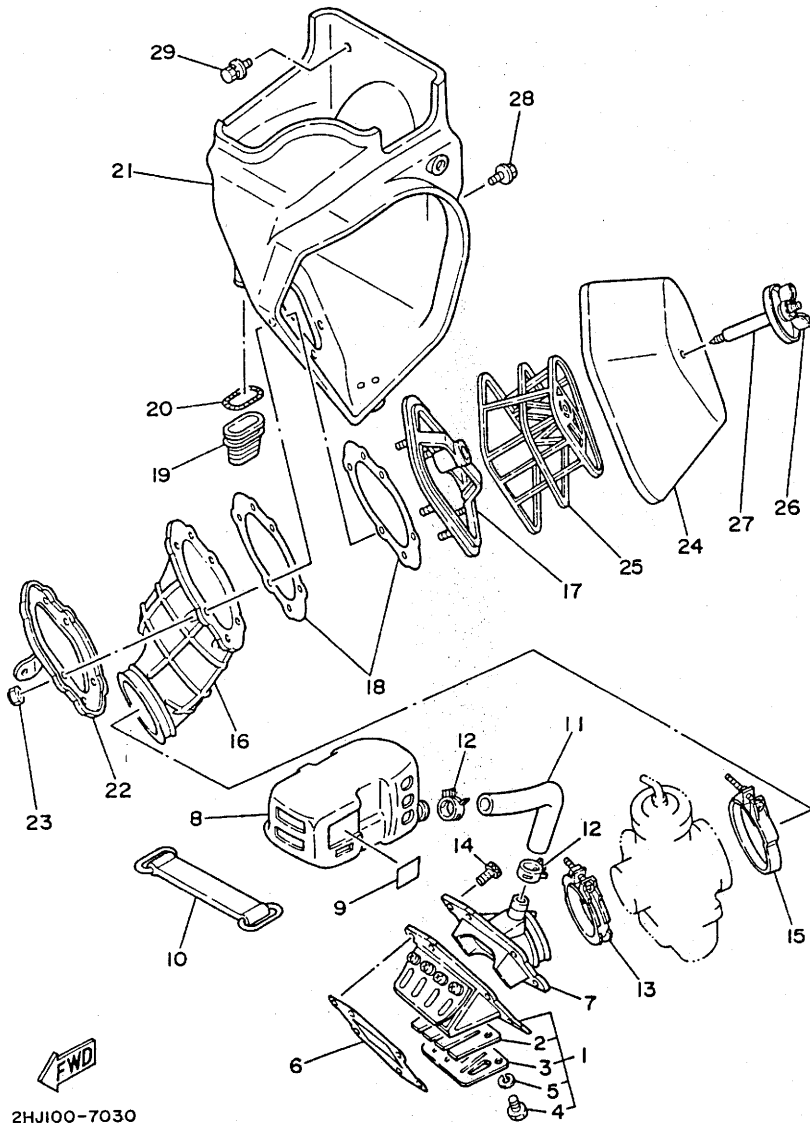

FWD
2HJ100-7030

B4

FIG. 3 INTAKE

REF. NO.	PART NO.	DESCRIPTION	Q'TY	REMARKS
29	90119-06056	BOLT, with washer	1	

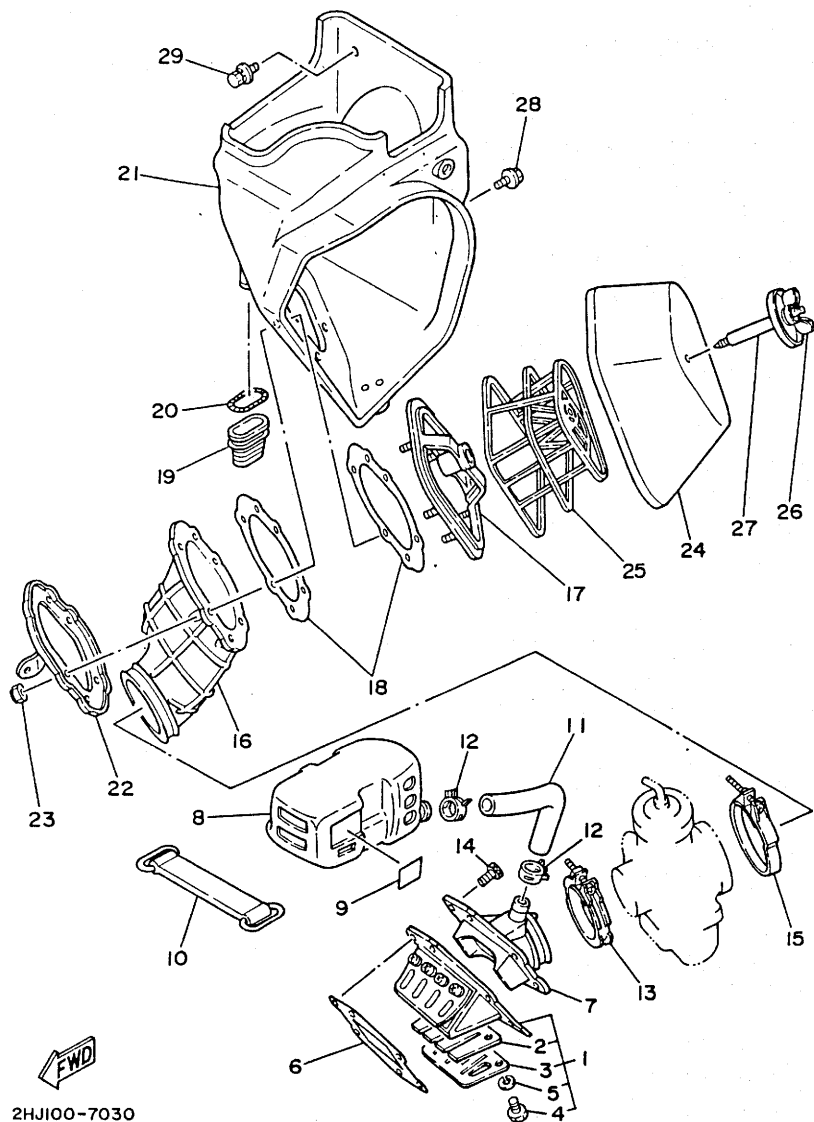

2HJ100-7030

FIG. 4 CARBURETOR

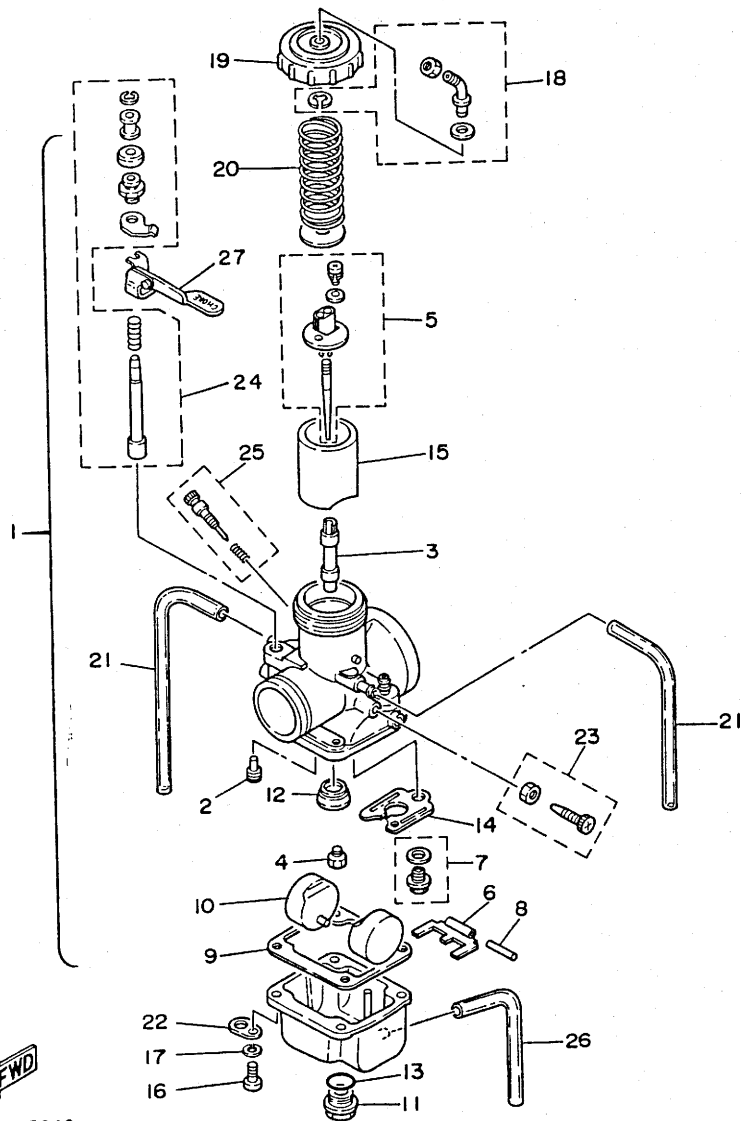

57H110-5040

REF. NO.	PART NO.	DESCRIPTION	Q'TY	REMARKS
1	2HJ-14101-00	CARBURETOR ASSY 1	1	
2	193-14142-40	.JET, pilot (# 40)	1	STD
	193-14142-35	.JET, pilot (# 35)	1	AP
	193-14142-45	.JET, pilot (# 45)	1	AP
3	8A7-14141-56	.NOZZLE, main (Q-6)	1	STD
	8A7-14141-54	.NOZZLE, main (Q-4)	1	AP
	8A7-14141-58	.NOZZLE, main (Q-8)	1	AP
4	137-14143-94	.JET, main (#470)	1	STD
	137-14143-90	.JET, main (#450)	1	AP
	137-14143-92	.JET, main (#460)	1	AP
	137-14143-96	.JET, main (#480)	1	AP
	137-14143-98	.JET, main (#237.5)	1	AP
5	2HJ-1490J-00	.NEEDLE SET	1	
6	40T-14187-00	.ARM, float	1	
7	23X-14107-35	.NEEDLE VALVE SET	1	
8	537-14186-00	.PIN, float	1	
9	363-14184-00	.GASKET, float chamber	1	
10	214-14185-00	.FLOAT	2	
11	40T-14115-00	.PLUG, screw	1	
12	3R3-14153-00	.WASHER, main jet	1	
13	278-14117-00	.WASHER, plug screw	1	
14	40T-14146-00	.PLATE	1	
15	40T-14112-30	.VALVE, throttle 1	1	STD
	40T-14112-25	.VALVE, throttle 1	1	AP
	40T-14112-35	.VALVE, throttle 1	1	AP
16	98501-05016	.SCREW, pan head	4	
17	92901-05100	.WASHER, spring	4	
18	40T-14106-00	.CABLE ADJUST SCREW SET	1	

B6

FIG. 4 CARBURETOR

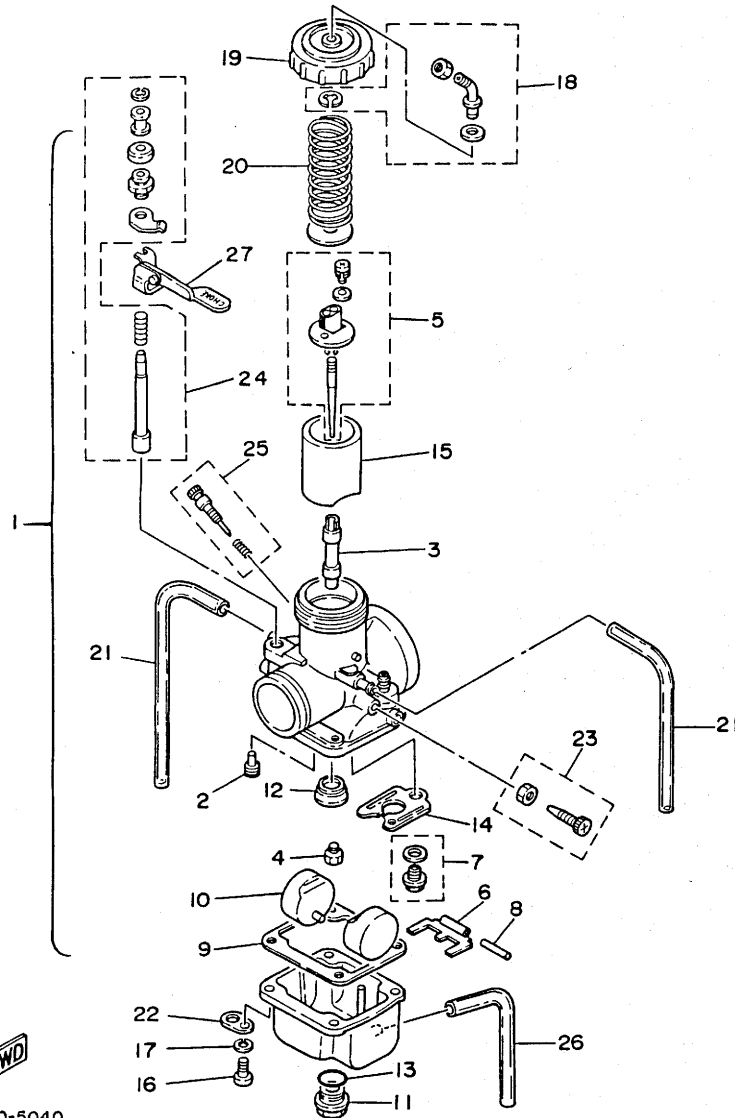

REF. NO.	PART NO.	DESCRIPTION	Q'TY	REMARKS
19	40T-14158-00	.TOP, mixing chamber	1	
20	8H0-14131-00	.SPRING, throttle valve	1	
21	2HH-14197-00	.PIPE	2	
22	313-14146-00	.PLATE	2	
23	40T-14103-00	.THROTTLE SCREW SET	1	
24	57H-1410A-00	.STARTER SET	1	
25	23X-14104-00	.AIR SCREW SET	1	
26	2K7-14197-00	.PIPE	2	
27	57H-14175-00	.LEVER, starter 1	1	



57H110-5040

B7

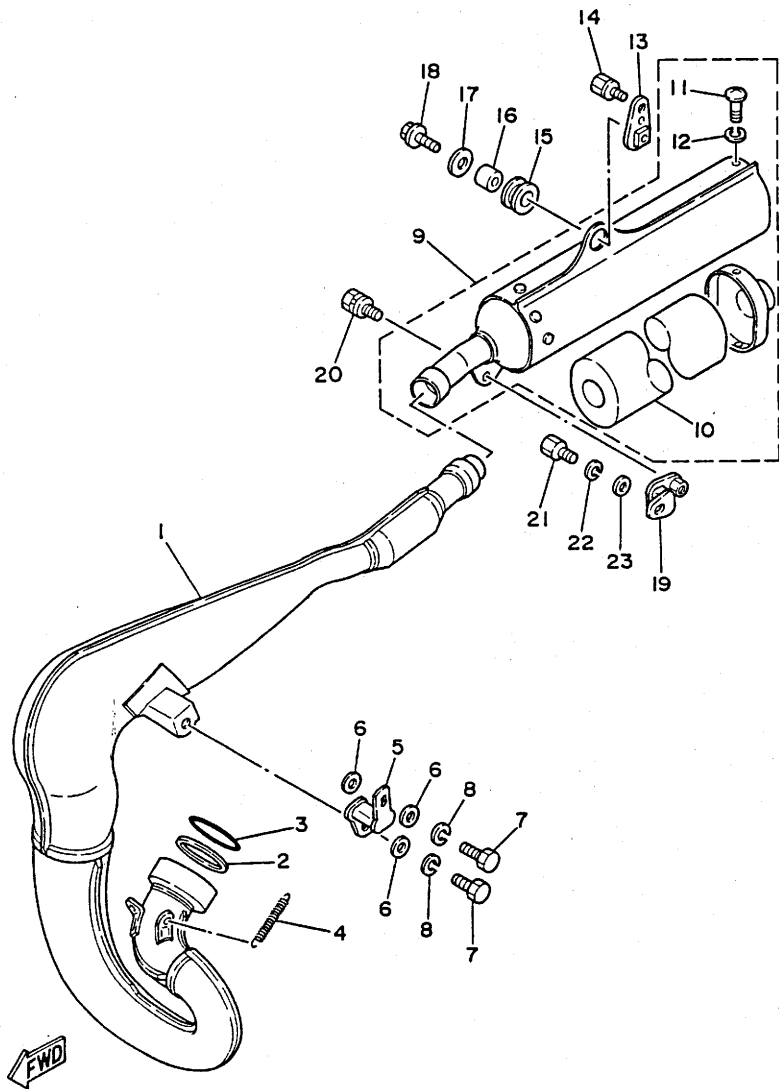

2HJ100-7050

FIG. 5 EXHAUST

REF. NO.	PART NO.	DESCRIPTION	Q'TY	REMARKS
1	2HJ-14610-00	EXHAUST PIPE ASSY 1	1	
2	2HJ-14613-00	GASKET, exhaust pipe	1	
3	93210-65752	O-RING	1	
4	90507-20030	SPRING, tension	3	
5	40T-14771-00	STAY, muffler 1	1	
6	90201-08730	WASHER, plate	3	
7	97313-08016	BOLT	2	
8	92990-08100	WASHER, spring	2	
9	2HJ-14753-00	SILENCER, exhaust	1	
10	2HJ-1469A-00	.FIBER	1	
11	92501-06010	.SCREW, pan head	2	
12	92990-06100	.WASHER, spring	2	
13	1LX-14744-00	BRACKET	1	
14	90109-08573	BOLT	1	
15	39X-14747-00	DAMPER, muffler	1	
16	90387-081A3	COLLAR	1	
17	90201-08612	WASHER, plate	1	
18	95821-08025	BOLT, flange	1	
19	565-14771-00	STAY, muffler 1	1	
20	90109-06551	BOLT	1	
21	97313-06016	BOLT	1	
22	92990-06100	WASHER, spring	1	
23	92901-06600	WASHER, plate	1	

FIG. 6 CRANKCASE

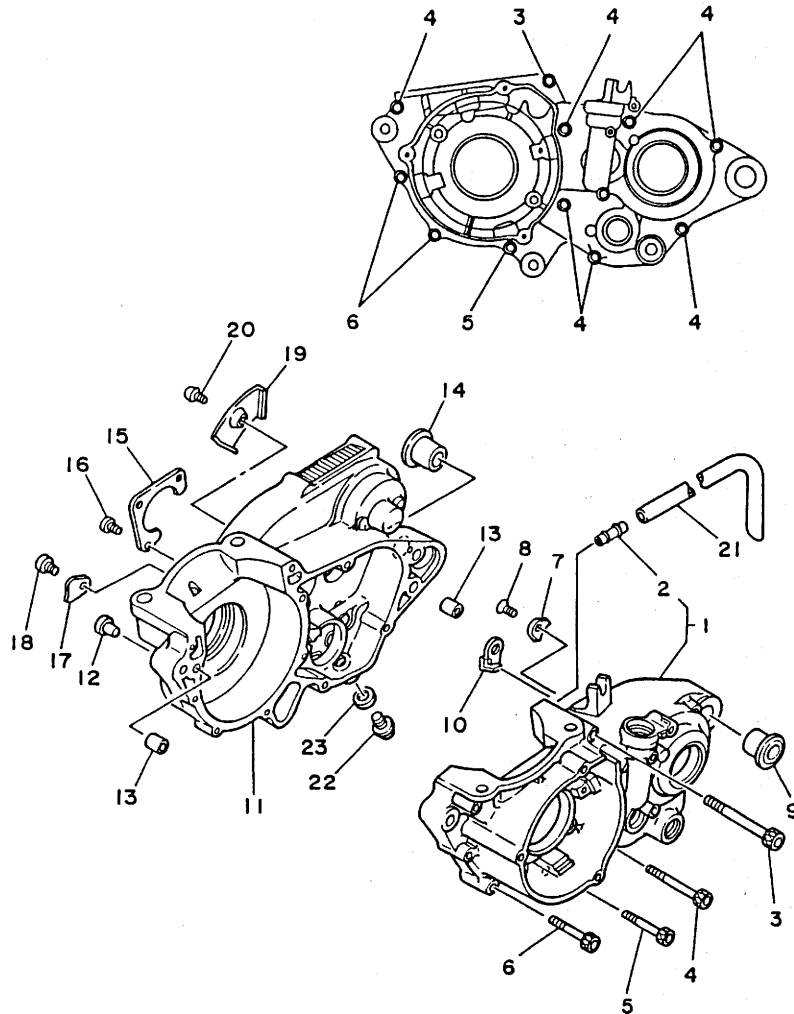

REF. NO.	PART NO.	DESCRIPTION	Q'TY	REMARKS
1	3R5-W1511-01	CRANKCASE 1	1	
2	137-13115-00	.CONNECTOR, suction pipe	1	
3	91316-06075	BOLT	1	
4	91316-06060	BOLT	7	
5	91316-06050	BOLT	1	
6	91316-06045	BOLT	2	
7	56A-15383-00	PLATE, bearing cover	1	
8	92701-06012	SCREW, flat head	1	
9	90387-160H4	COLLAR	1	
10	23X-26393-00	HOLDER	1	
11	3R5-15121-05	CRANKCASE 2	1	
12	90338-07011	PLUG	1	
13	99510-12016	PIN, dowel	4	
14	90387-160H4	COLLAR	1	
15	23X-15381-00	PLATE, bearing cover	1	
16	92501-06012	SCREW, pan head	3	
17	4V4-15118-00	HOLDER	1	
18	92501-06010	SCREW, pan head	1	
19	3R4-15113-00	PLATE	1	
20	92501-06012	SCREW, pan head	1	
21	90445-08605	HOSE	1	
22	90340-12095	PLUG, straight screw	1	
23	90430-12038	GASKET	1	



ILV100-6060

B9

FIG. 7 CRANKCASE COVER 1

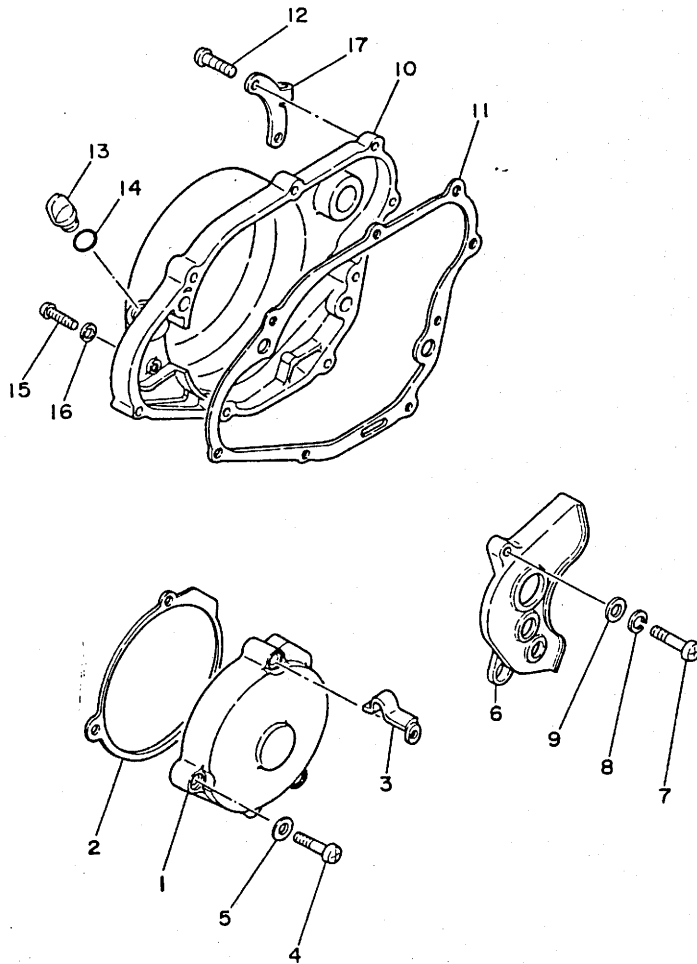

REF. NO.	PART NO.	DESCRIPTION	Q'TY	REMARKS
1	40T-15411-00	COVER, crankcase 1	1	
2	1LV-15451-00	GASKET, crankcase cover 1	1	
3	90465-06247	CLAMP	1	
4	92506-06035	SCREW, pan head	3	
5	92906-06600	WASHER, plate	3	
6	23X-15421-00	COVER, crankcase 2	1	
7	92506-06025	SCREW, pan head	1	
8	92906-06100	WASHER, spring	1	
9	92906-06600	WASHER, plate	1	
10	40T-15431-00	COVER, crankcase 3	1	
11	3R4-15462-00	GASKET, crankcase cover 3	1	
12	91316-06025	BOLT	8	
13	1G8-15362-00	PLUG, oil level	1	
14	93210-14104	O-RING	1	
15	92506-06008	SCREW, pan head	1	
16	90430-06016	GASKET	1	
17	56A-15378-00	HOLDER	1	



57H110-5070

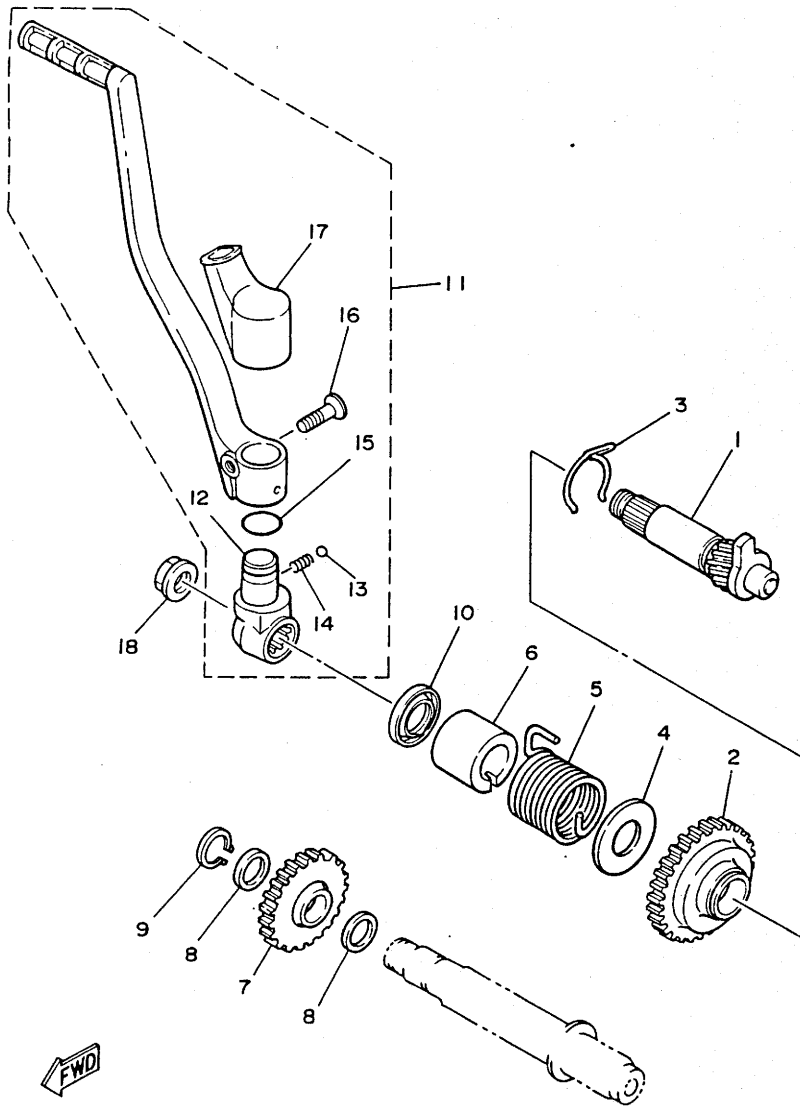
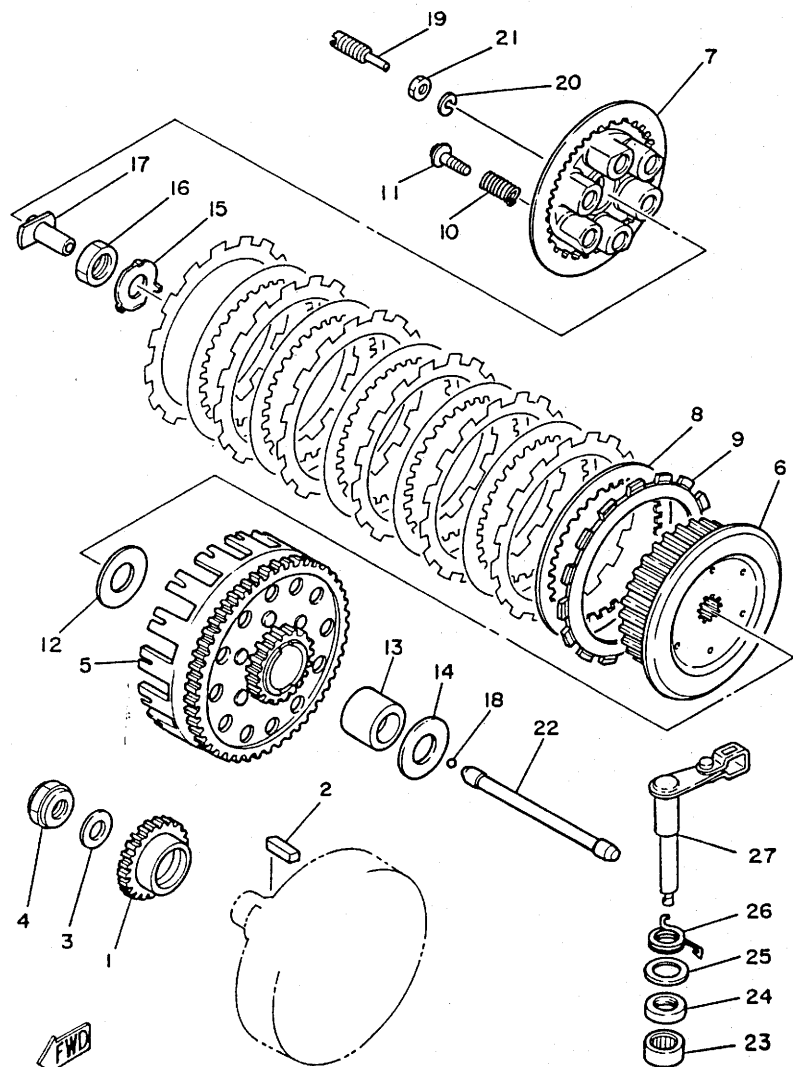

FIG. 8 STARTER

REF. NO.	PART NO.	DESCRIPTION	Q'TY	REMARKS
1	57H-15661-00	AXLE, kick	1	
2	23X-15641-00	GEAR, kick	1	
3	90468-26177	CLIP	1	
4	90201-20358	WASHER, plate	1	
5	90508-30422	SPRING, torsion	1	
6	40T-15664-00	GUIDE, spring	1	
7	23X-15651-00	GEAR, kick idle	1	
8	90201-17545	WASHER, plate	2	
9	99009-17400	CIRCLIP	1	
10	93102-20309	OIL SEAL	1	
11	40T-15620-01	KICK CRANK ASSY	1	
12	23X-15621-01	.BOSS, kick crank	1	
13	93501-04011	.BALL	1	
14	90501-13720	.SPRING, compression	1	
15	93210-19501	.O-RING	1	
16	90152-06010	.SCREW, countersunk	1	
17	23X-15618-00	.COVER, kick lever	1	
18	90179-12244	NUT	1	

23X100-3091

B11



57H110-5090

FIG. 9 CLUTCH

REF. NO.	PART NO.	DESCRIPTION	Q'TY	REMARKS
1	23X-16111-00	GEAR, primary drive	1	
2	90282-07019	KEY, straight	1	
3	90201-186H3	WASHER, plate	1	
4	90185-18126	NUT, self-locking	1	
5	39X-16150-00	PRIMARY DRIVEN GEAR COMP.	1	
6	23X-16371-00	BOSS, clutch	1	
7	23X-16351-00	PLATE, pressure 1	1	
8	4H7-16325-00	PLATE, clutch 2	6	
9	5X5-16321-00	PLATE, friction	7	
10	90501-24408	SPRING, compression	6	
11	90159-06016	SCREW, with washer	6	
12	2K7-16154-00	PLATE, thrust 1	1	
13	2K7-16181-00	SPACER 1	1	
14	2K7-16154-00	PLATE, thrust 1	1	
15	90215-20212	WASHER, lock	1	
16	90170-20255	NUT	1	
17	23X-16356-00	ROD, push 1	1	
18	93515-32029	BALL	1	
19	90149-06179	SCREW	1	
20	92990-06100	WASHER, spring	1	
21	95303-06600	NUT	1	
22	3R5-16357-01	ROD, push 2	1	
23	93315-21721	BEARING, cylindrical	1	
24	93102-17263	OIL SEAL	1	
25	90201-17327	WASHER, plate	1	
26	90508-14423	SPRING, torsion	1	
27	1LV-16380-00	PUSH LEVER ASSY	1	

FIG. 10 TRANSMISSION

REF. NO.	PART NO.	DESCRIPTION	Q'TY	REMARKS
1	1LV-17411-00	AXLE, main (15T)	1	
2	93300-20501	BEARING (TM205C3)	1	
3	1LV-17141-00	GEAR, 4th pinion (22T)	1	
4	90201-253K0	WASHER, plate	1	
5	93440-25084	CIRCLIP	2	
6	1LV-17131-01	GEAR, 3rd pinion	1	
7	90209-22082	WASHER	1	
8	1LV-17151-00	GEAR, 5th pinion (24T)	1	
9	1LV-17121-00	GEAR, 2nd pinion (16T)	1	
10	90209-20213	WASHER	1	
11	93311-62035	BEARING, cylindrical	1	
12	5X5-17421-00	AXLE, drive	1	
13	1LV-17221-00	GEAR, 2nd wheel (24T)	1	
14	90201-253K0	WASHER, plate	1	
15	93440-25084	CIRCLIP	3	
16	1LV-17251-00	GEAR, 5th wheel (20T)	1	
17	90209-22082	WASHER	2	
18	1LV-17231-00	GEAR, 3rd wheel (22T)	1	
19	1LV-17241-00	GEAR, 4th wheel (22T)	1	
20	1LV-17211-00	GEAR, 1st wheel (29T)	1	
21	90201-20278	WASHER, plate	1	
22	93410-20038	CIRCLIP	1	
23	93311-62035	BEARING, cylindrical	1	
24	93300-20501	BEARING (TM205C3)	1	
25	93102-32M07	OIL SEAL	1	
26	90387-25663	COLLAR	1	
27	3Y1-17461-40	SPROCKET, drive (14T)	1	STD
	23X-17461-30	SPROCKET, drive (13T)	1	AP

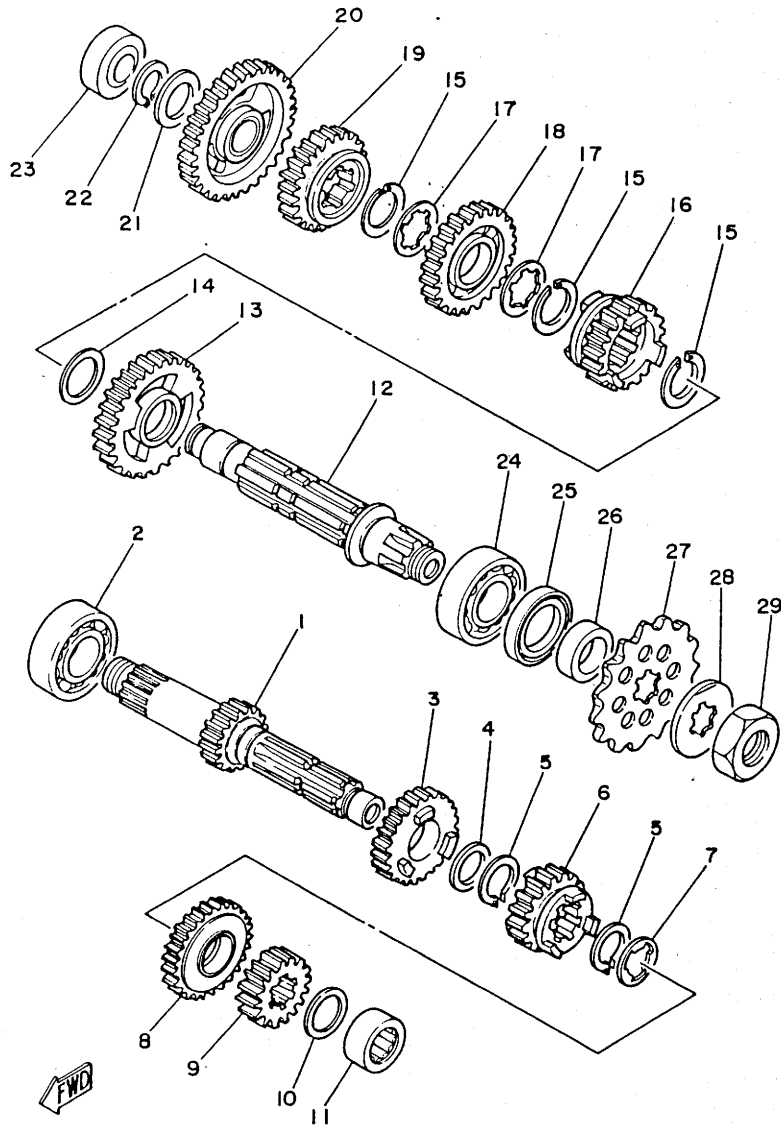

1LV100-6100

B13

FIG. 10 TRANSMISSION

REF. NO.	PART NO.	DESCRIPTION	Q'TY	REMARKS
27	3Y1-17461-50	SPROCKET, drive (15T)	1	AP
28	90215-21239	WASHER, lock	1	
29	90179-20255	NUT	1	

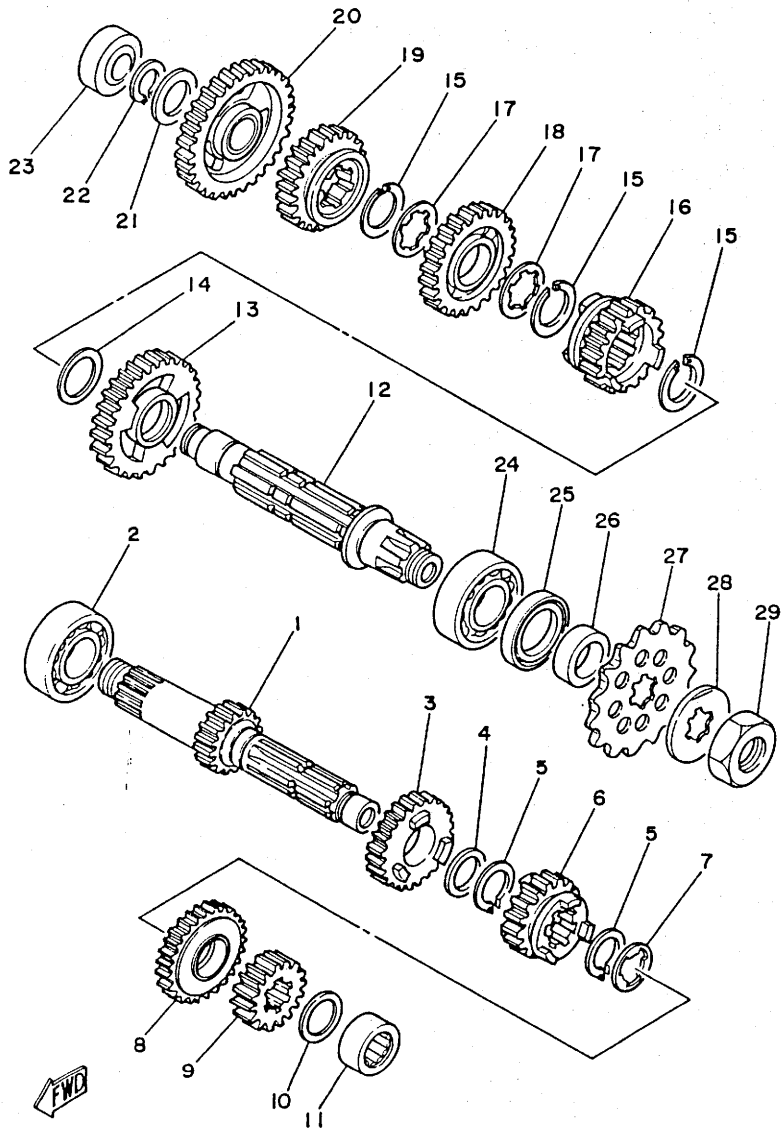

ILV100-6100



B14

FIG. 11 SHIFT CAM. FORK

REF. NO.	PART NO.	DESCRIPTION	Q'TY	REMARKS
1	24Y-18540-00	SHIFT CAM ASSY	1	
2	3R4-18140-00	STOPPER LEVER ASSY	1	
3	90508-26421	SPRING, torsion	1	
4	50W-21631-00	BOLT 1	1	
5	5X5-18511-00	FORK, shift 1	1	
6	3R5-18512-00	FORK, shift 2	1	
7	5X5-18513-00	FORK, shift 3	1	
8	93606-14154	PIN, dowel	3	
9	5X5-18531-01	BAR, shift fork guide 1	1	
10	5X5-18535-01	BAR, shift fork guide 2	1	
11	93306-20107	BEARING (B6201)	1	

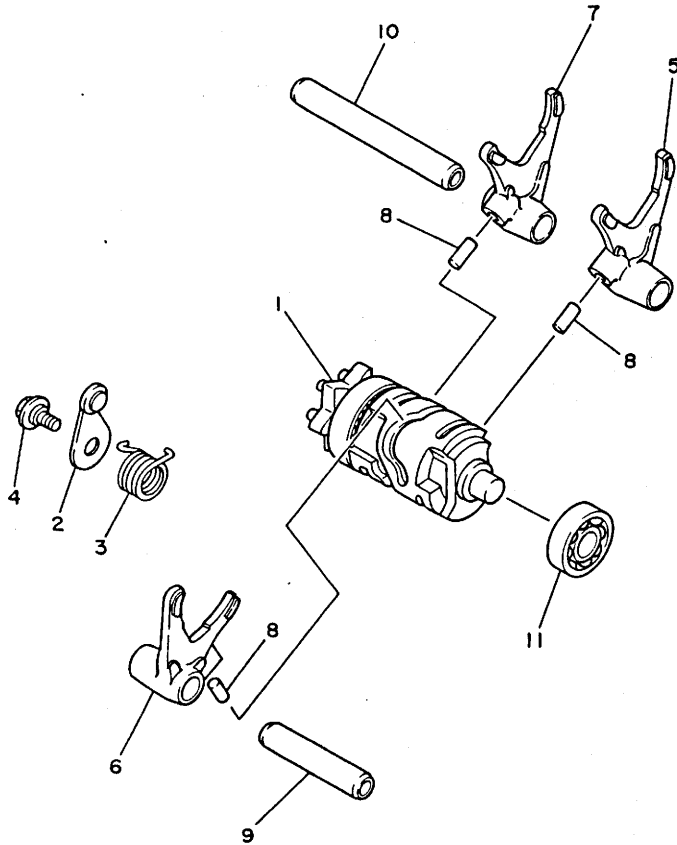

24Y100-3150

B15

FIG. 12 SHIFT SHAFT

REF. NO.	PART NO.	DESCRIPTION	Q'TY	REMARKS
1	23X-18101-00	SHIFT SHAFT ASSY	1	
2	23X-18110-01	SHIFT PEDAL ASSY	1	
3	97311-06025	BOLT	1	
4	93608-25150	PIN, dowel	1	
5	93102-12106	OIL SEAL	1	
6	90560-12171	SPACER	1	
7	90508-29361	SPRING, torsion	1	

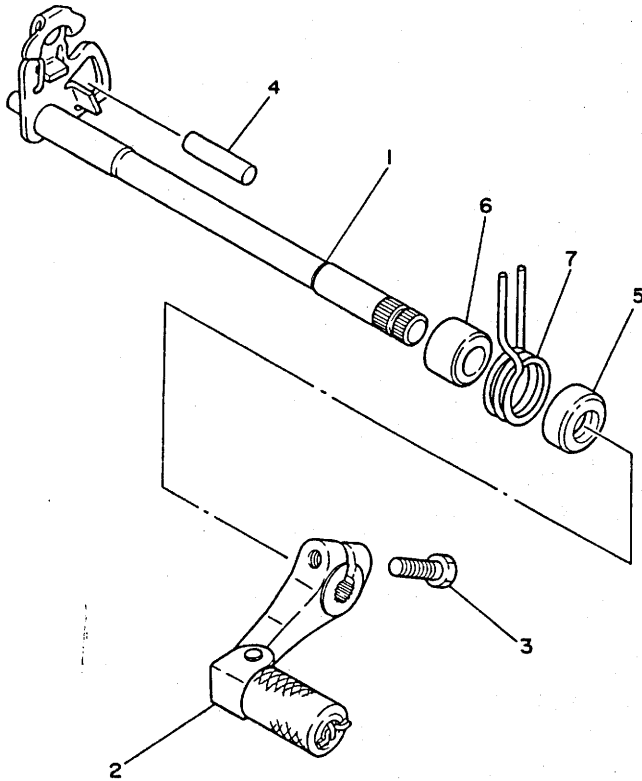

24Y100-3160

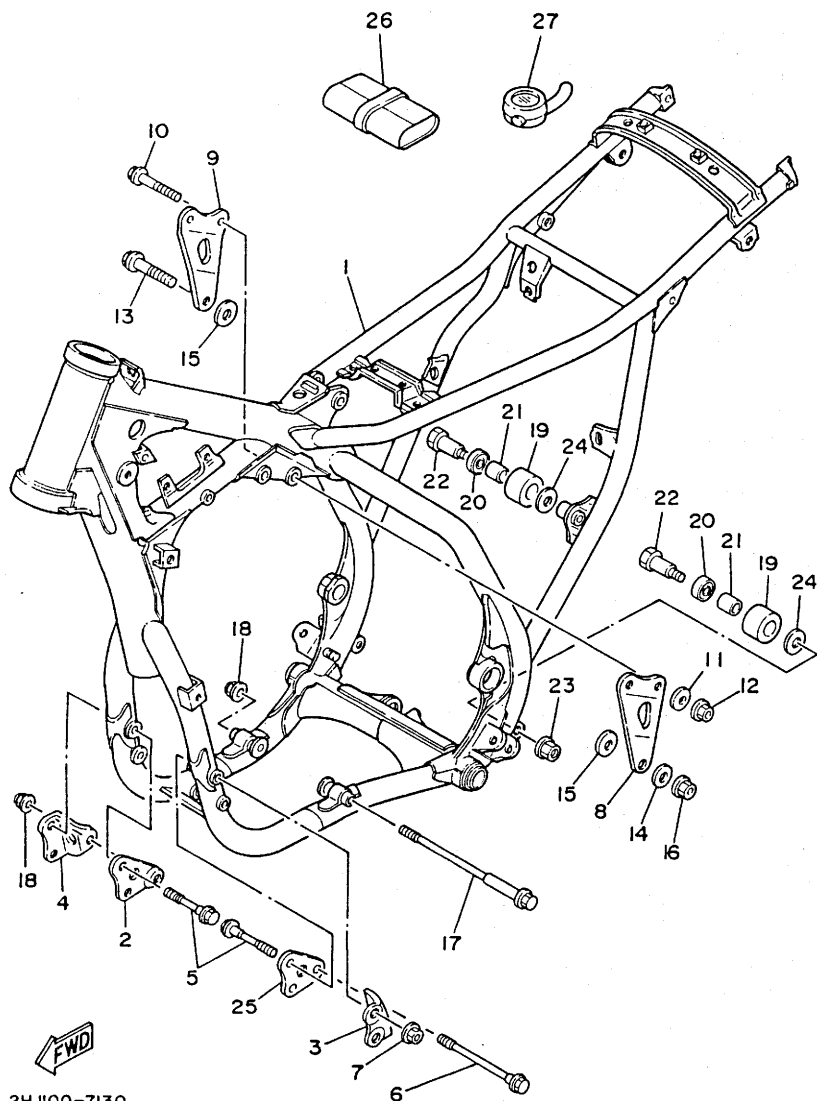

2HJ100-7130

FIG. 13 FRAME

REF. NO.	PART NO.	DESCRIPTION	Q'TY	REMARKS
1	2HJ-21110-00-UJ	FRAME COMP.	1	RADICAL WHITE
2	40T-21416-00	BRACKET, front upper 2	1	
3	40T-2141K-00	BRACKET, outer 1	1	
4	40T-2141L-00	BRACKET, outer 2	1	
5	90105-08107	BOLT, washer based	4	
6	90105-08214	BOLT, washer based	1	
7	90185-08113	NUT, self-locking	4	
8	1LV-21425-00	BRACKET, rear upper 1	1	
9	1LV-21426-00	BRACKET, rear upper 2	1	
10	95811-08055	BOLT, flange	2	
11	90202-08022	WASHER, plate	2	
12	90185-08113	NUT, self-locking	2	
13	95811-10065	BOLT, flange	1	
14	92901-10200	WASHER, plain	1	
15	90201-101J1	WASHER, plate	2	
16	90179-10280	NUT	1	
17	90105-08449	BOLT, washer based	1	
18	90185-08113	NUT, self-locking	2	
19	2HH-22178-00	TENSIONER	2	
20	93300-60816	BEARING	2	
21	90387-086N4	COLLAR	2	
22	95021-08045	BOLT, flange	2	
23	90185-08106	NUT, self-locking	1	
24	90201-081A6	WASHER, plate	2	
25	40T-21415-00	BRACKET, front upper 1	1	
26	1LV-28100-00	TOOL KIT	1	
27	2X4-2811A-00	GAUGE, air	1	

FIG. 14 FENDER

REF. NO.	PART NO.	DESCRIPTION	Q'TY	REMARKS
1	5X6-21511-10	FENDER, front	1	WHITE
2	90387-06681	COLLAR	4	
3	90119-06063	BOLT, with washer	4	
4	1LX-21611-00	FENDER, rear	1	WHITE
5	90201-06571	WASHER, plate	4	
6	90105-06138	BOLT, washer based	4	
7	437-83936-00	BAND, switch cord	1	
8	39X-21642-00	GUARD, flap	1	
9	90119-06117	BOLT, with washer	2	

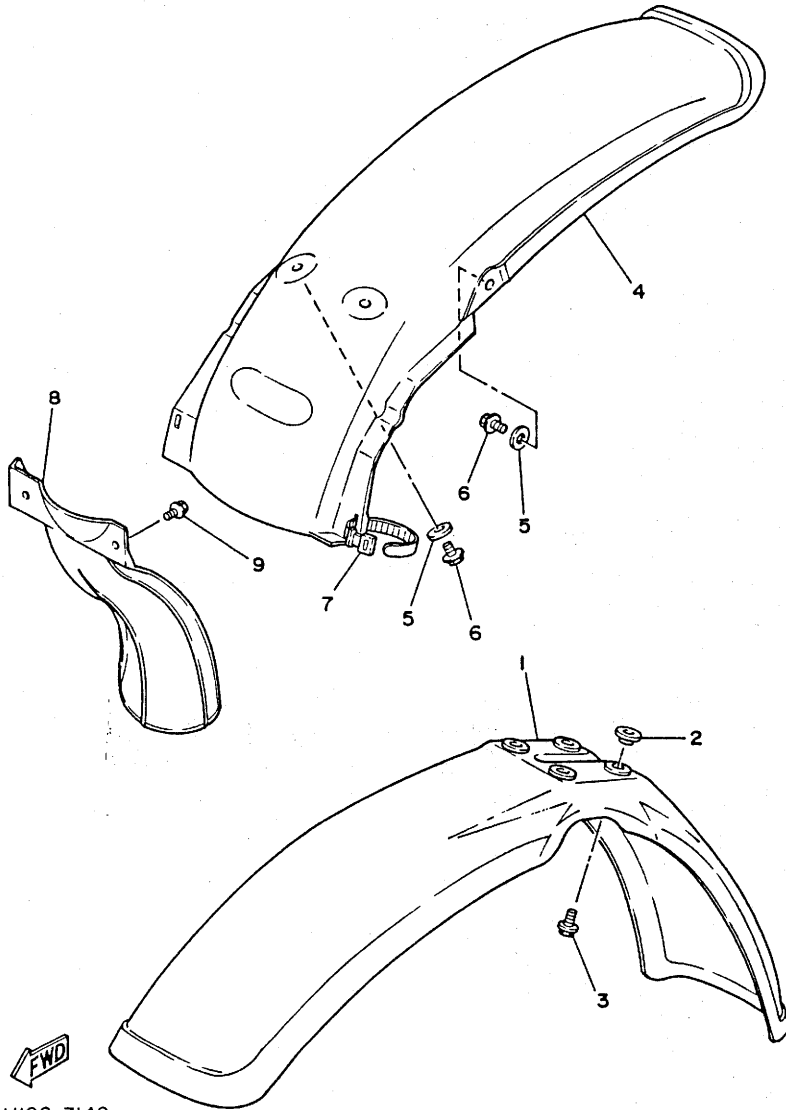

FWD

2HJ100-7140

C4

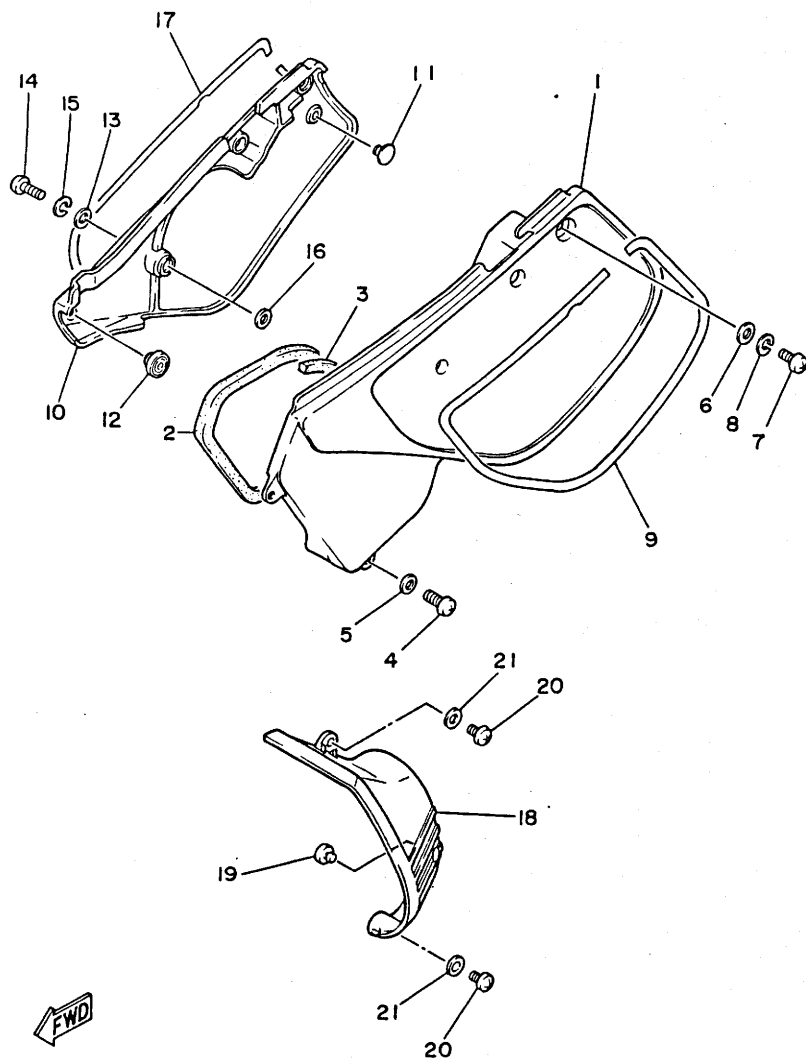

FIG. 15 SIDE COVER

REF. NO.	PART NO.	DESCRIPTION	Q'TY	REMARKS
1	1LX-21711-01-98	COVER, side 1	1	LOW GLOSS BLACK
2	1LX-14452-00	SEAL	1	
3	39X-14452-00	SEAL	1	
4	92506-06016	SCREW, pan head	3	
5	92906-06600	WASHER, plate	3	
6	90201-06571	WASHER, plate	1	
7	92501-06014	SCREW, pan head	1	
8	92990-06100	WASHER, spring	1	
9	2HH-2173L-00	GRAPHIC SET 1	1	
10	1LX-21721-00	COVER, side 2	1	WHITE
11	22W-24181-00	DAMPER, locating 1	1	
12	2HJ-24741-00	PAD, seat	1	
13	90201-06571	WASHER, plate	2	
14	92501-06014	SCREW, pan head	2	
15	92990-06100	WASHER, spring	2	
16	92901-08200	WASHER, plain	2	
17	2HH-2174L-00	GRAPHIC SET 2	1	
18	43R-2137W-00	SCOOP, air 1	1	
19	22W-24181-00	DAMPER, locating 1	1	
20	92506-06016	SCREW, pan head	2	
21	90201-061E8	WASHER, plate	2	



2HJ100-7150

C5

FIG. 16 REAR ARM

REF. NO.	PART NO.	DESCRIPTION	Q'TY	REMARKS
1	1LV-22110-01	REAR ARM COMP.	1	
2	93317-32231	BEARING, cylindrical	4	
3	93106-22019	OIL SEAL	2	
4	93342-22208	BEARING	2	
5	93108-35004	OIL SEAL	2	
6	3R4-22129-00	COVER, thrust 2	2	
7	90380-16158	BUSH, solid	2	
8	90381-16060	BUSH, solid	1	
9	156-22127-00	SHIM (0.3T)	1	UN
10	1LX-22151-00	SEAL, guard	1	
11	98001-06020	BOLT	2	
12	90201-06067	WASHER, plate	2	
13	39W-22199-01	SUPPORT, chain	1	
14	95802-08045	BOLT, flange	2	
15	90185-08106	NUT, self-locking	2	
16	92901-08200	WASHER, plain	2	
17	1LX-22141-00	SHAFT, pivot	1	
18	90185-16127	NUT, self-locking	1	
19	90201-164H4	WASHER, plate	1	
20	1LX-2217A-00	ARM, relay	1	
21	93315-22046	BEARING, cylindrical	2	
22	93109-20029	OIL SEAL	4	
23	90387-164N2	COLLAR	2	
24	90387-164N3	COLLAR	2	
25	90402-10005	NUT, union	1	
26	95811-10016	BOLT, flange	1	
27	90201-106F2	WASHER, plate	1	
28	90101-14648	BOLT	1	

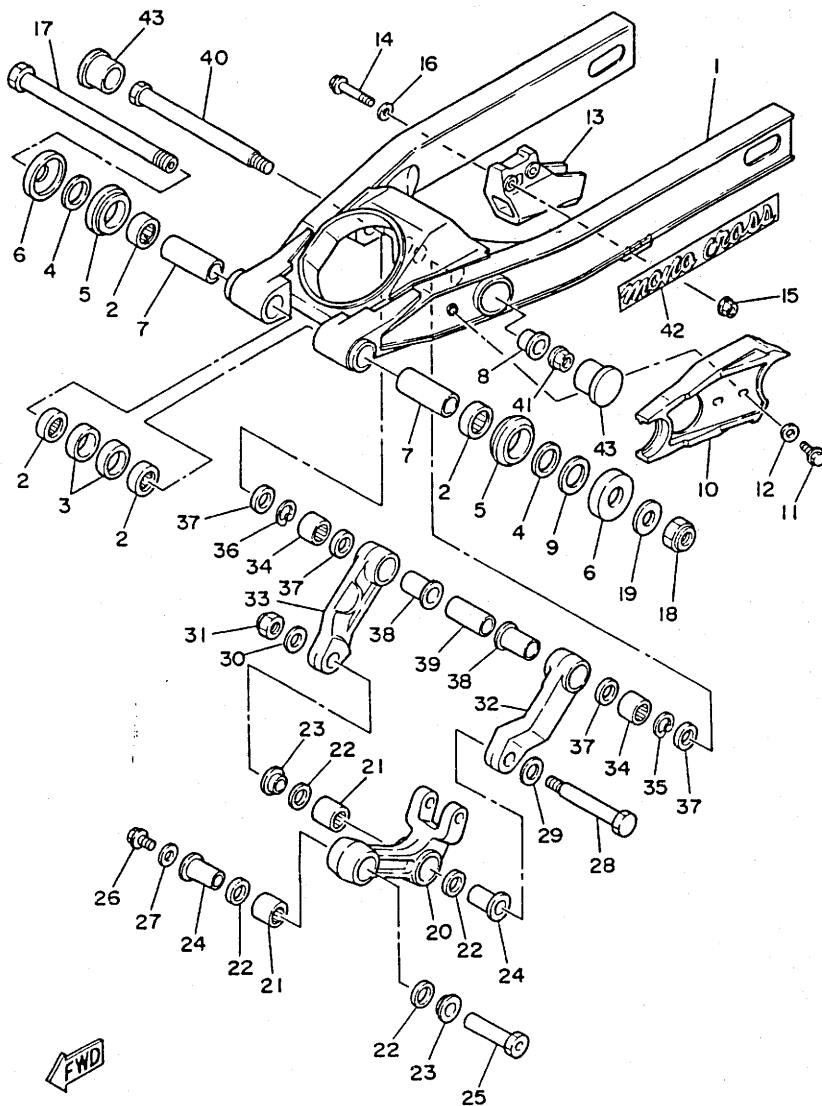

2HJ100-7160

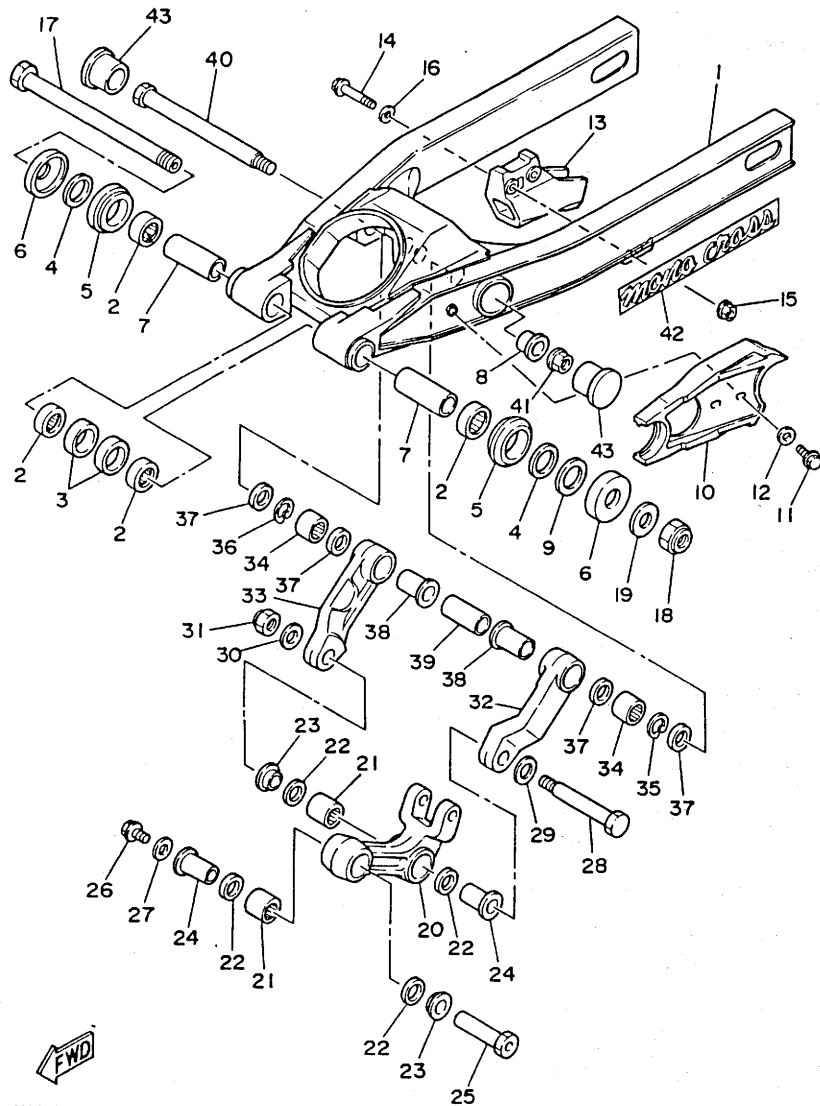

2HJ100-7160

FIG. 16 REAR ARM

REF. NO.	PART NO.	DESCRIPTION	Q'TY	REMARKS
29	90201-164H4	WASHER, plate	1	
30	90201-14740	WASHER, plate	1	
31	90185-14112	NUT, self-locking	1	
32	1LX-2217F-00	ROD, connecting 1	1	
33	1LX-2217G-00	ROD, connecting 2	1	
34	93315-22045	BEARING (YT202720E01)	2	IKO
35	93450-28063	CIRCLIP	1	
36	93450-28063	CIRCLIP	1	
37	93109-20029	OIL SEAL	4	
38	90387-164N3	COLLAR	2	
39	90387-164N1	COLLAR	1	
40	90123-14104	BOLT	1	
41	90185-14096	NUT, self-locking	1	
42	2HH-2218A-00	EMBLEM, rear arm	2	
43	1HX-2135F-00	COVER	2	

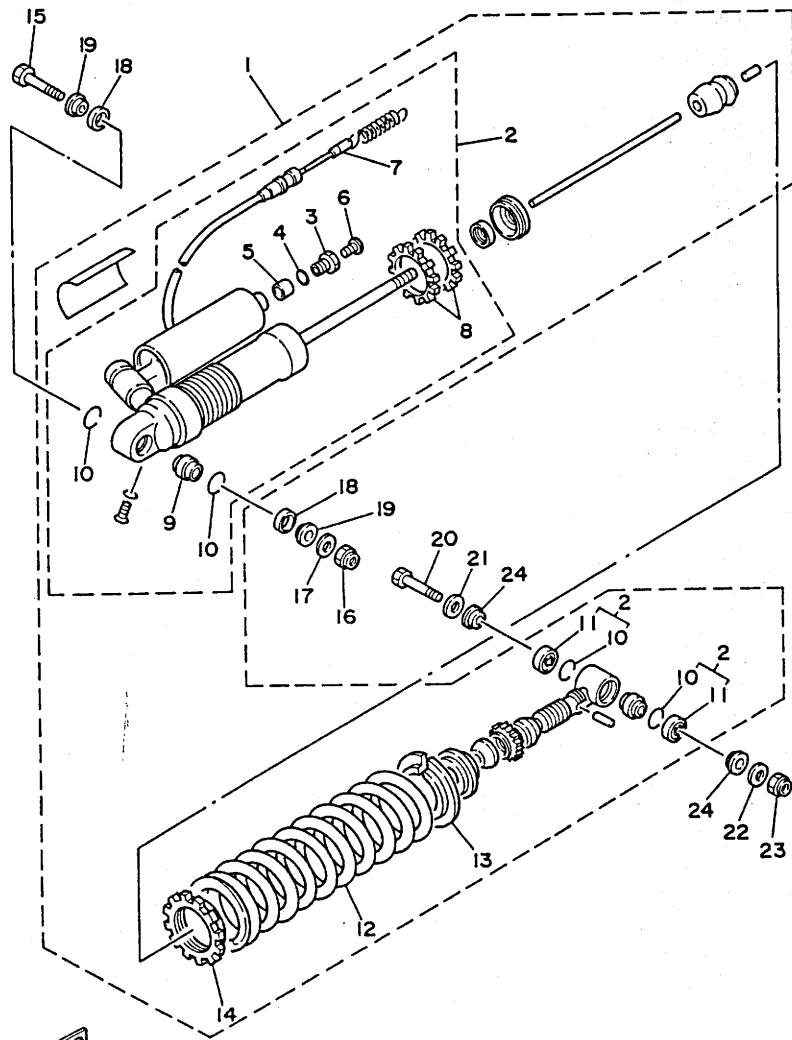

2HH100-7200

FIG. 17 REAR SUSPENSION

REF. NO.	PART NO.	DESCRIPTION	Q'TY	REMARKS
1	2HJ-22210-00-6W	SHOCK ABSORBER ASSY, rear	1	NATIVE RED
2	2HH-22201-00	.DAMPER SUB ASSY	1	
3	39W-22417-00	..PLUG	1	
4	93210-08483	..O-RING	1	
5	483-22419-01	..VALVE, rubber	1	
6	98501-04006	..SCREW, pan head	1	
7	1LV-22463-00	..CABLE, control 1	1	
8	1LX-22225-00	..RING, hold	2	
9	93399-99916	..BEARING	2	
10	93440-30113	..CIRCLIP	4	
11	93104-18077	..OIL SEAL	2	
12	1LV-22212-00-6W	.SPRING (K=5.5)	1	NATIVE RED
13	5X6-22214-00	.GUIDE, spring 1	2	
14	1LX-22223-00	.SEAT, spring lower	1	
15	90109-10704	BOLT	1	
16	90185-10120	NUT, self-locking	1	
17	90201-100F7	WASHER, plate	1	
18	23X-22211-00	COVER	2	
19	90387-127G8	COLLAR	2	
20	90109-10700	BOLT	1	
21	90201-120E6	WASHER, plate	1	
22	90201-100E9	WASHER, plate	1	
23	90185-10120	NUT, self-locking	1	
24	90387-126H8	COLLAR	2	

FIG. 18 STEERING

REF. NO.	PART NO.	DESCRIPTION	Q'TY	REMARKS
1	3R4-23389-00	GUIDE, cable	1	
2	93332-00008	BEARING	1	
3	40T-23435-00-98	CROWN, handle	1	LOW GLOSS BLACK
4	1E6-23442-00	HOLDER, handle lower	2	
5	307-22123-00	BUSH 1	2	
6	90201-123E8	WASHER, plate	2	
7	90201-100A1	WASHER, plate	2	
8	90387-121E8	COLLAR	2	
9	90202-14077	WASHER, plate	2	
10	90185-10037	NUT, self-locking	2	
11	91401-20020	PIN, cotter	2	
12	90105-08091	BOLT, washer based	4	
13	1E6-23441-00	HOLDER, handle upper	2	
14	95821-08035	BOLT, flange	4	
15	93332-00023	BEARING	1	
16	1W1-23416-00	COVER, ball race 2	1	
17	90179-25033	NUT	1	
18	90179-22330	NUT	1	
19	5X6-23485-11	PLATE, number	1	CLEAN WHITE
20	92501-06012	SCREW, pan head	1	
21	90201-06571	WASHER, plate	1	
22	1LX-23395-00	EMBLEM	1	
23	34K-2319U-00	CAP	1	

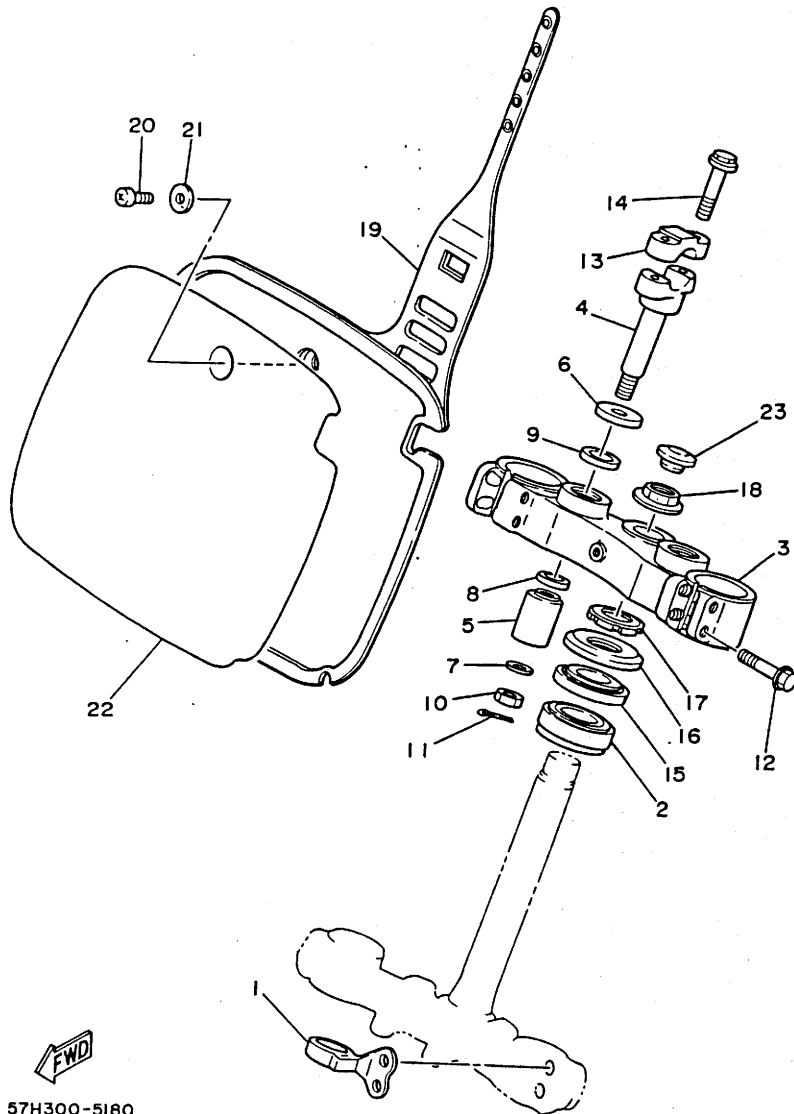

57H300-5180

FIG. 19 FRONT FORK

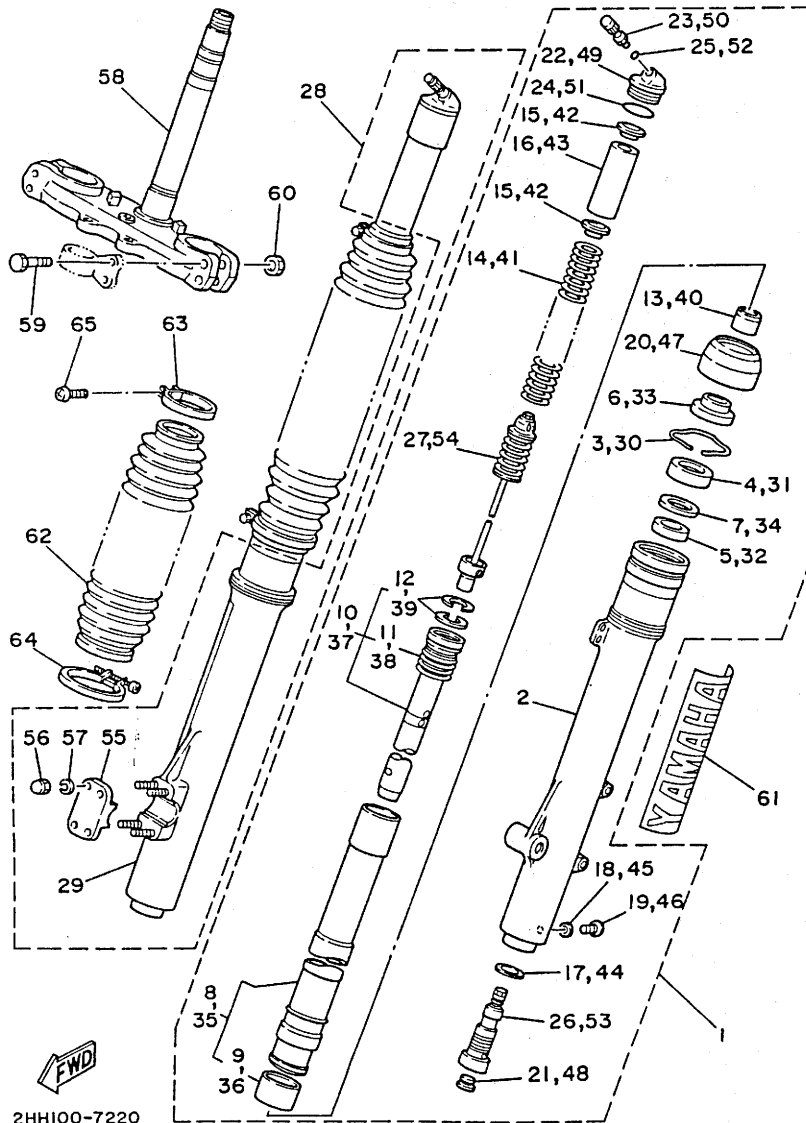

REF. NO.	PART NO.	DESCRIPTION	Q'TY	REMARKS
1	2HH-23102-L0	FRONT FORK ASSY (L.H.)	1	
2	2HH-23126-L0	.TUBE, outer 1	1	
3	4V4-23153-L0	.RING, snap	1	
4	23X-23145-L0	.OIL SEAL	1	
5	4V4-23125-L0	.METAL, slide 1	1	
6	23X-23144-L0	.SEAL, dust	1	
7	4V4-23146-L0	.WASHER, oil seal	1	
8	2HH-23110-L0	.INNER TUBE COMP.1	1	
9	4V4-23171-L0	..PISTON, front fork	1	
10	2HH-23170-L0	.CYLINDER COMP., front fork	1	
11	2HH-23151-L0	..SPRING, sub	1	
12	4V4-23157-L0	..RING, piston	2	
13	2HH-23173-L0	.SPINDLE, taper	1	
14	2HH-23141-L0	.SPRING, front fork (K=0.375)	1	
15	4V4-23142-L0	.SEAT, spring upper	2	
16	2HH-23118-L0	.SPACER (L=57)	1	
17	2HH-23158-L0	.GASKET	1	
18	122-23129-00	.GASKET, drain plug	1	
19	4H7-23119-00	.PLUG, drain	1	
20	1LX-23144-L0	.SEAL, dust	1	
21	55Y-2312G-M0	.PLUG	1	
22	43M-23111-L0	.BOLT, cap	1	
23	23X-23190-L0	.AIR VALVE COMP.	1	
24	4V4-23188-L0	.O-RING	1	
25	3J2-23147-00	.O-RING	1	
26	2HH-2316A-L0	.VALVE COMP.	1	
27	2HH-2318R-00	.ADJUSTER	1	
28	2HH-23103-L0	FRONT FORK ASSY (R.H.)	1	

C10

FIG. 19 FRONT FORK

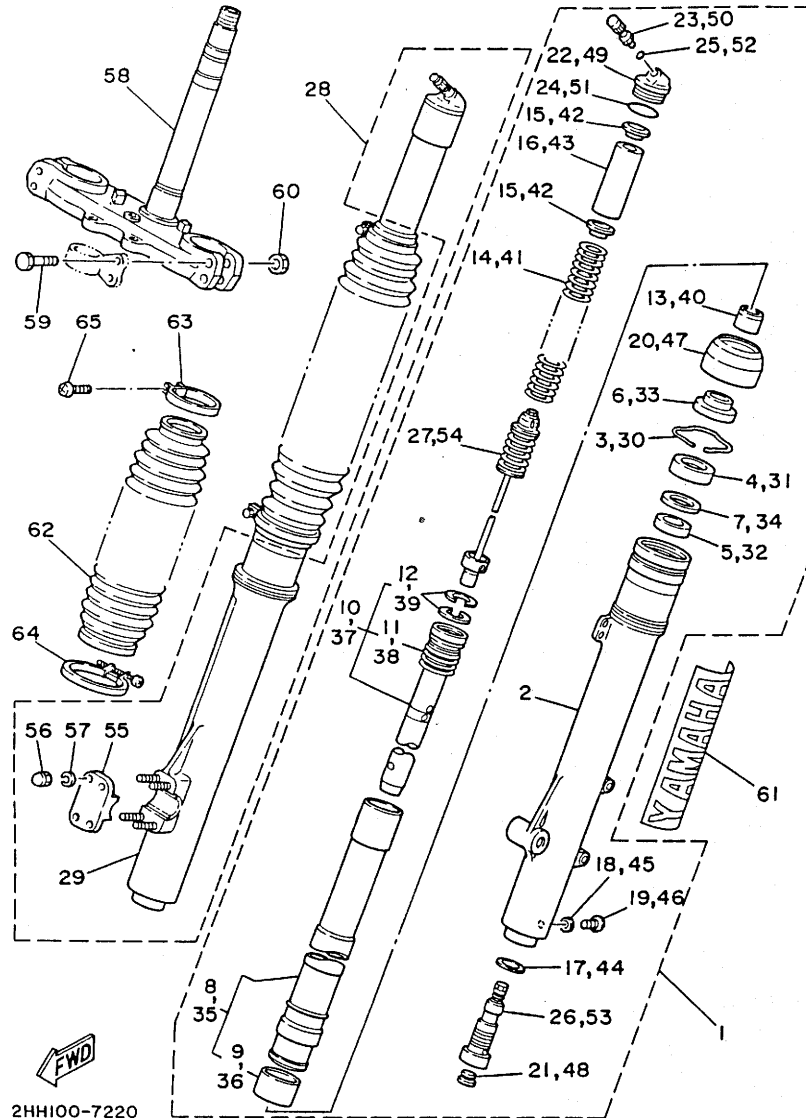

2HH100-7220

REF. NO.	PART NO.	DESCRIPTION	Q'TY	REMARKS
29	2HH-23136-L0	.TUBE, outer 2	1	
30	4V4-23153-L0	.RING, snap	1	
31	23X-23145-L0	.OIL SEAL	1	
32	4V4-23125-L0	.METAL, slide 1	1	
33	23X-23144-L0	.SEAL, dust	1	
34	4V4-23146-L0	.WASHER, oil seal	1	
35	2HH-23110-L0	.INNER TUBE COMP.1	1	
36	4V4-23171-L0	..PISTON, front fork	1	
37	2HH-23170-L0	.CYLINDER COMP., front fork	1	
38	2HH-23151-L0	..SPRING, sub	1	
39	4V4-23157-L0	..RING, piston	2	
40	2HH-23173-L0	.SPINDLE, taper	1	
41	2HH-23141-L0	.SPRING, front fork (K=0.375)	1	
42	4V4-23142-L0	.SEAT, spring upper	2	
43	2HH-23118-L0	.SPACER (L=57)	1	
44	2HH-23158-L0	.GASKET	1	
45	122-23129-00	.GASKET, drain plug	1	
46	4H7-23119-00	.PLUG, drain	1	
47	1LX-23144-L0	.SEAL, dust	1	
48	55Y-2312G-M0	.PLUG	1	
49	43M-23111-L0	.BOLT, cap	1	
50	23X-23190-L0	.AIR VALVE COMP.	1	
51	4V4-23188-L0	.O-RING	1	
52	3J2-23147-00	.O-RING	1	
53	2HH-2316A-L0	.VALVE COMP.	1	
54	2HH-2318R-00	.ADJUSTER	1	
55	1LX-23167-L0	.HOLDER, axle	1	
56	5Y3-23393-00	.NUT, special	4	

FIG. 19 FRONT FORK

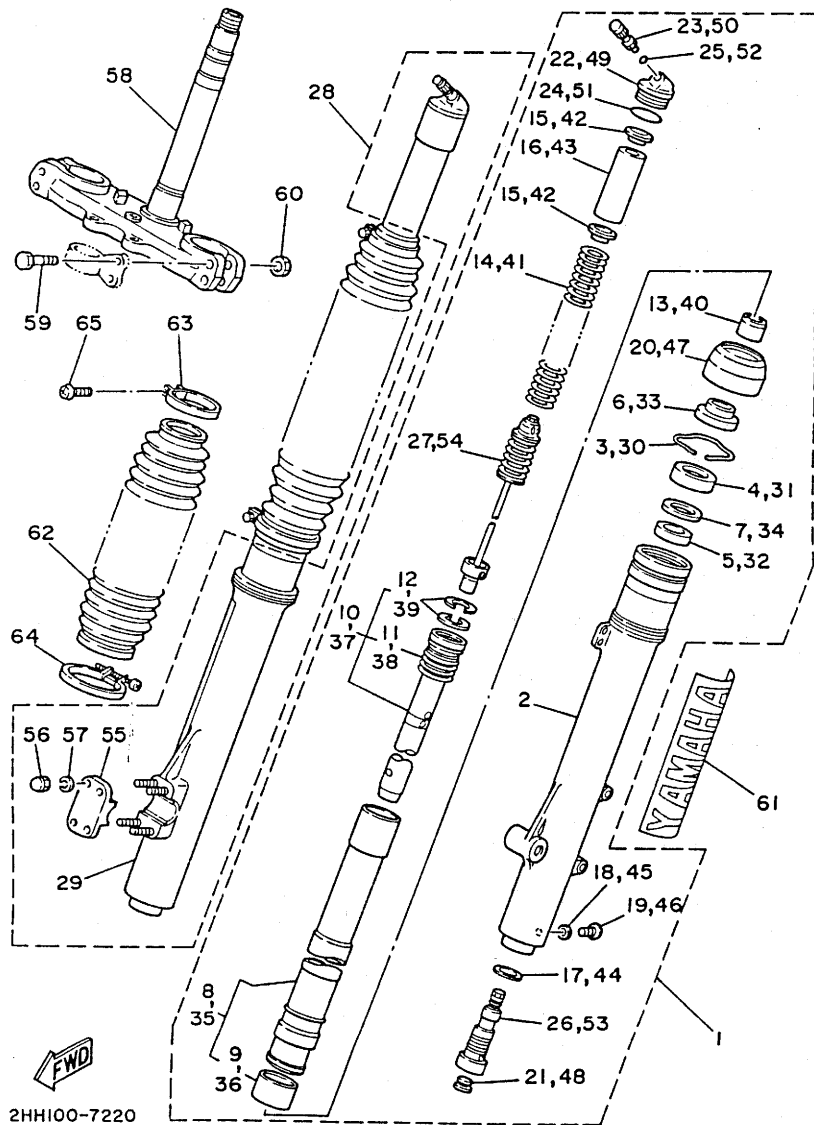

REF. NO.	PART NO.	DESCRIPTION	Q'TY	REMARKS
57	92990-06100	.WASHER, spring	4	
58	2HH-23340-LO	UNDER BRACKET COMP.	1	
59	95821-08055	BOLT, flange	4	
60	95701-08500	NUT, flange	4	
61	1LX-23108-00	EMBLEM	2	
62	43M-23191-LO	BOOT	2	RED
63	43M-23192-LO	BAND	2	
64	43M-23489-LO	BAND	2	
65	98506-04018	SCREW, pan head	2	

2HH100-7220

C12

FIG. 20 FUEL TANK

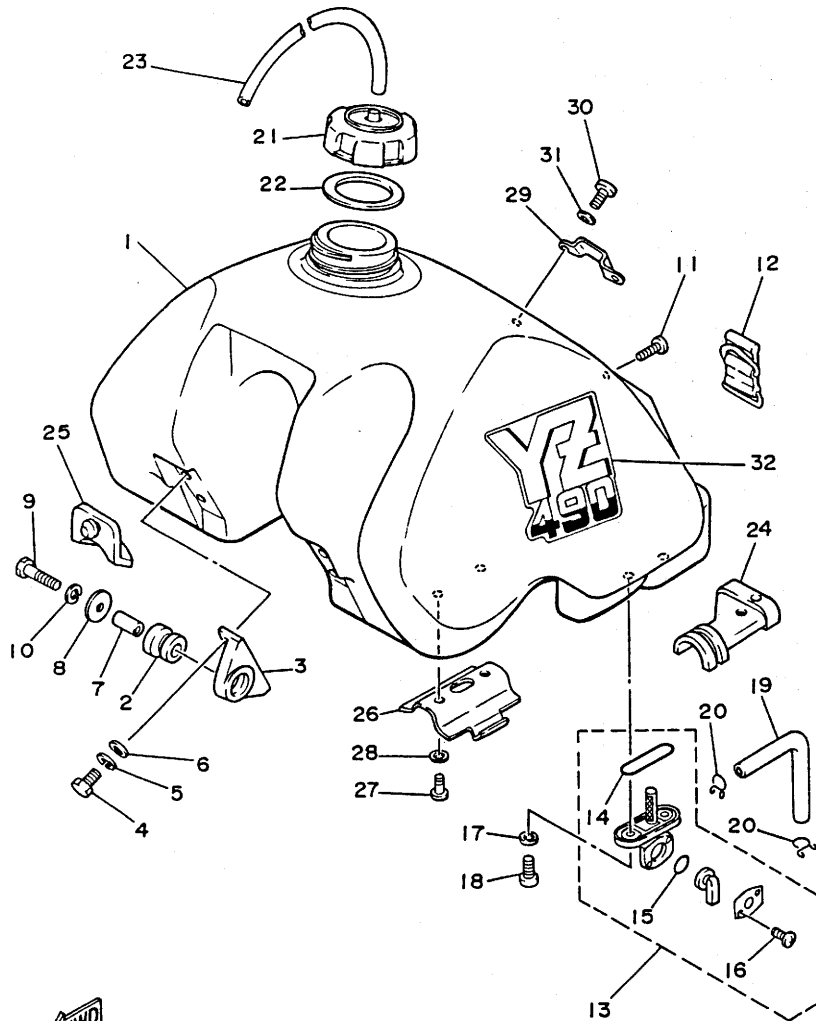

REF. NO.	PART NO.	DESCRIPTION	Q'TY	REMARKS
1	1LV-24110-00	FUEL TANK COMP.	1	WHITE
2	90480-18354	GROMMET	2	
3	24X-24144-00	HOLDER, damper	2	
4	97313-06016	BOLT	4	
5	92990-06100	WASHER, spring	4	
6	92901-06600	WASHER, plate	4	
7	90387-06387	COLLAR	2	
8	90201-06070	WASHER, plate	2	
9	97313-06035	BOLT	2	
10	92990-06100	WASHER, spring	2	
11	98980-06020	SCREW, bind	1	
12	59V-24173-00	BAND, tank fitting 1	1	
13	1LX-24500-00	FUEL COCK ASSY 1	1	
14	4X8-24512-00	.GASKET	1	
15	4X8-24534-00	.SEAL, cock	1	
16	97801-03008	.SCREW, pan head	2	
17	90202-06010	WASHER, plate	2	
18	90149-06011	SCREW	2	
19	90445-112E9	HOSE	1	
20	90467-10008	CLIP	2	
21	5X7-24611-01	BODY, cap	1	
22	5X7-24612-00	GASKET, cap	1	
23	90445-09100	HOSE	1	
24	1LX-24181-00	DAMPER, locating 1	1	
25	23X-24184-00	DAMPER, locating 4	1	
26	5X6-2415F-01	STAY, chamber	1	
27	92501-06010	SCREW, pan head	2	
28	92901-06600	WASHER, plate	2	

FWD
2HJ100-7200

FIG. 20 FUEL TANK

REF. NO.	PART NO.	DESCRIPTION	Q'TY	REMARKS
29	40T-2412F-00	BRACKET, seat	1	
30	92501-06012	SCREW, pan head	2	
31	92901-06600	WASHER, plate	2	
32	2HJ-24254-00	GRAPHIC, fuel tank 7	2	

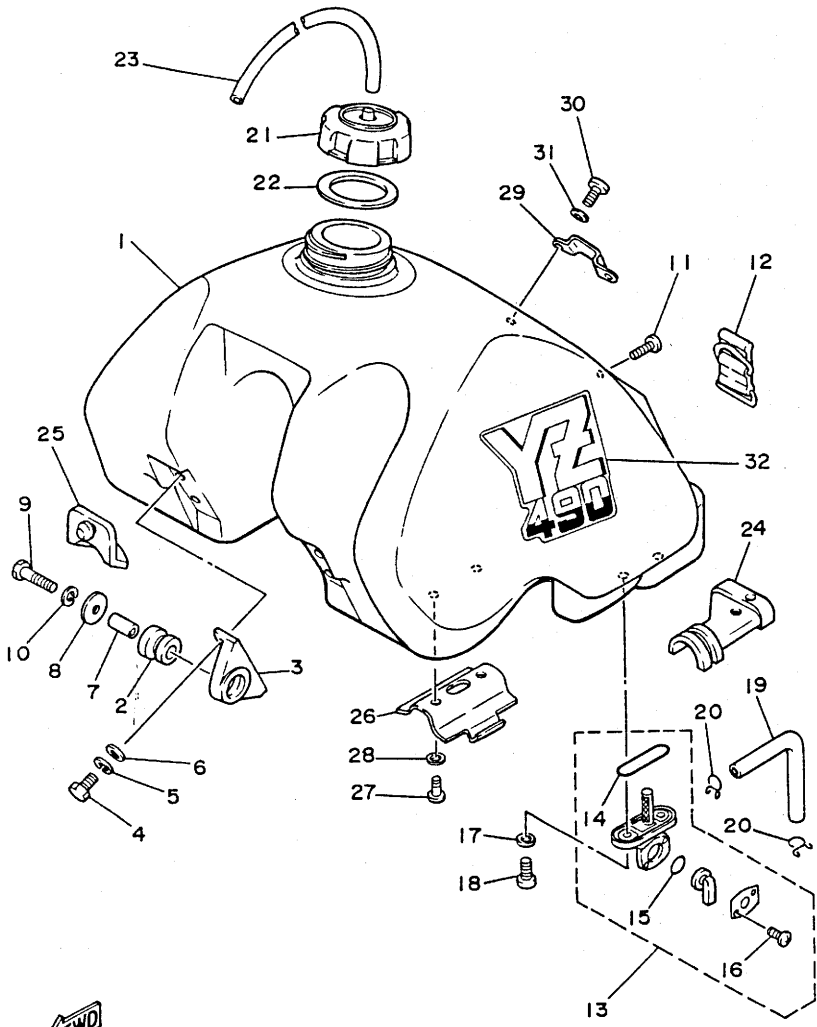

2HJ100-7200

FIG. 21 SEAT

REF. NO.	PART NO.	DESCRIPTION	Q'TY	REMARKS
1	1LX-24770-00	SEMI-DOUBLE SEAT ASSY	1	CHAPPY RED
2	1LX-24731-00	.COVER, seat	1	CHAPPY RED
3	5X6-24748-10	.BRACKET, seat	1	
4	92501-06012	.SCREW, pan head	2	
5	92901-06600	.WASHER, plate	2	
6	1LX-24738-01	.BRACKET, seat	2	
7	95801-06012	.BOLT, flange	4	
8	509-24724-00	.DAMPER, seat	1	
9	107-24741-00	.PAD, seat	2	
10	95023-08016	BOLT, flange	2	

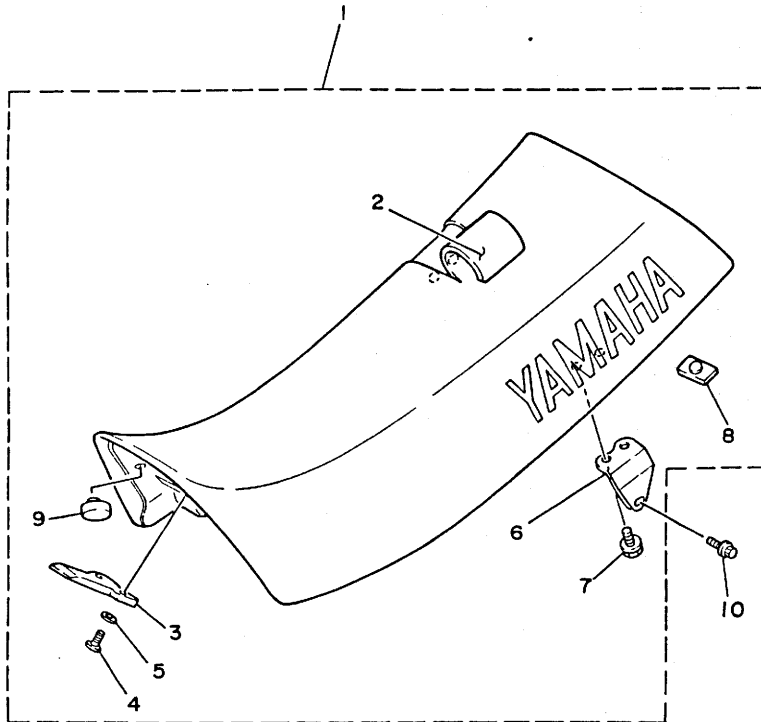

2HJ100-7210

C15

FIG. 22 FRONT WHEEL

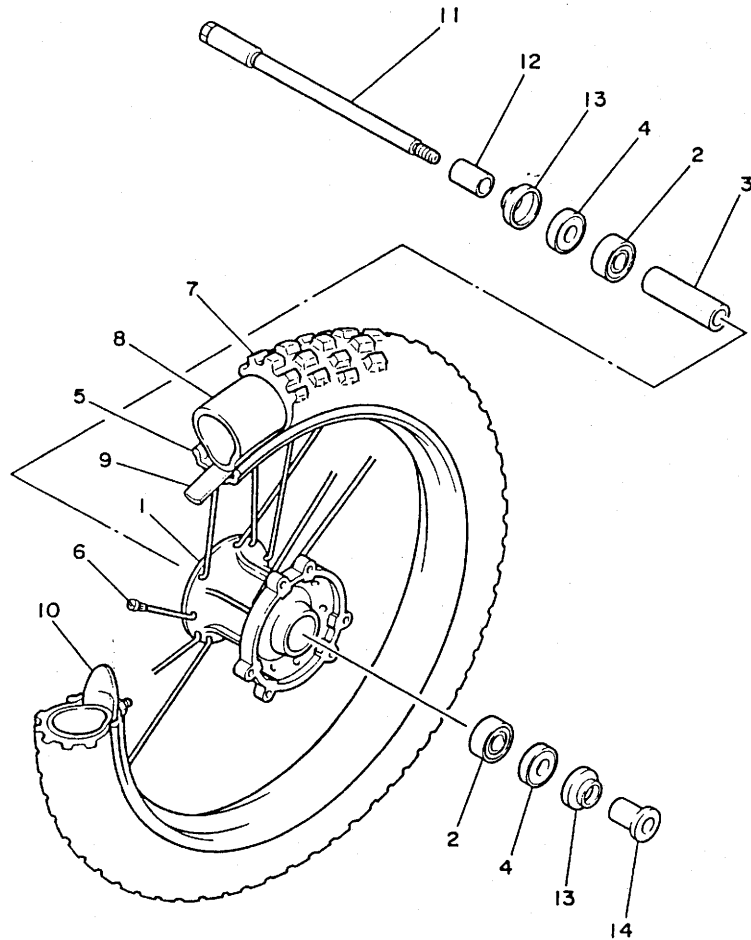

REF. NO.	PART NO.	DESCRIPTION	Q'TY	REMARKS
1	2HH-25111-00-98	HUB, front	1	LOW GLOSS BLACK
2	93306-20209	BEARING (B6202)	2	
3	90560-15240	SPACER	1	
4	93102-20281	OIL SEAL	2	
5	94416-21435	RIM (1.60-21)	1	GOLD
6	1LX-25104-00	SPOKE SET, front	1	
7	94108-215N7	TIRE	1	DUNLOP
8	94227-21123	TUBE (2.75-21)	1	BRIDGESTONE
9	94307-21145	BAND, rim (70-80/100-21)	1	DUNLOP
10	2J5-25394-01	SPACER, bead	1	
11	55U-25181-00	AXLE, wheel	1	
12	90387-157L9	COLLAR	1	
13	322-25118-00	COVER, hub dust	2	
14	90387-156R7	COLLAR	1	



ILX010-6250

D2

FIG. 23 FRONT BRAKE CALIPER

REF. NO.	PART NO.	DESCRIPTION	Q'TY	REMARKS
1	1LX-25831-00	DISC, brake (RIGHT)	1	
2	90109-06757	BOLT	6	
3	2HH-25810-00	CALIPER ASSY (RIGHT)	1	
4	56A-W0057-00	.PISTON ASSY, caliper	1	
5	56A-W0047-00	..CALIPER SEAL KIT	1	
6	5R2-25917-00	.BOOT, caliper	1	
7	56A-25937-00	.BOOT 2	1	
8	51L-W0048-00	.BREED SCREW KIT	1	
9	56A-25919-00	.SUPPORT, pad	1	
10	56A-25919-10	.SUPPORT, pad	1	
11	2HH-W0045-00	.BRAKE PAD KIT, front	1	
12	56A-25926-00	.BOLT	1	
13	34X-25845-00	.CAP, indicator	1	
14	95811-08045	BOLT, flange	2	

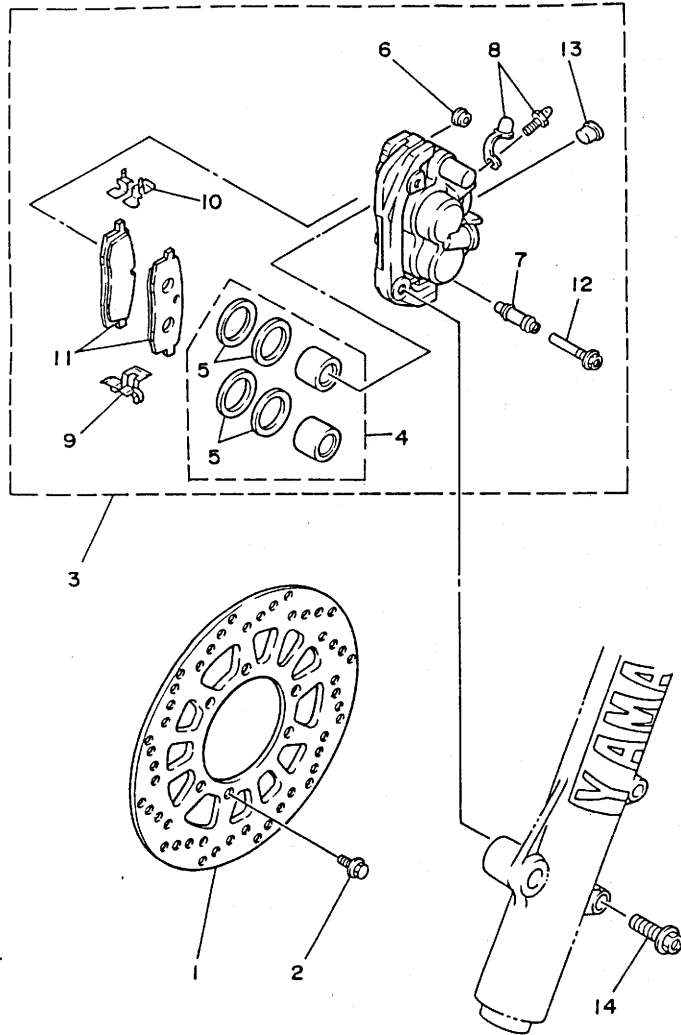

1LX010-6260

D3

FIG. 24 REAR WHEEL

REF. NO.	PART NO.	DESCRIPTION	Q'TY	REMARKS
1	57H-25311-00-98	HUB, rear	1	LOW GLOSS BLACK.
2	90560-20226	SPACER	1	
3	93306-00418	BEARING	2	
4	93306-00406	BEARING (B6004Z)	2	
5	93106-28023	OIL SEAL	1	
6	40T-25321-00-98	PLATE, brake shoe	1	LOW GLOSS BLACK
7	40T-W2536-00	BRAKE SHOE SET	1	
8	90507-20002	SPRING, tension	2	
9	40T-25351-00	CAMSHAFT	1	
10	5X6-25355-00	LEVER, camshaft	1	
11	90101-06291	BOLT	1	
12	90387-200H1	COLLAR	1	
13	90508-29641	SPRING, torsion	1	
14	93109-14021	OIL SEAL	1	
15	148-25353-00	SHIM, camshaft	1	
16	94425-18415	RIM (2.50-18)	1	
17	57H-25304-00	SPOKE SET, rear	1	
18	94112-186N1	TIRE	1	DUNLOP
19	94212-18188	TUBE (120/90-18)	1	DUNLOP
20	94309-18146	BAND, rim	1	DUNLOP
21	2X5-25394-00	SPACER, bead	2	
22	39W-25448-00	SPROCKET, driven (48T)	1	STD
	39W-25444-00	SPROCKET, driven (44T)	1	AP
	39W-25445-00	SPROCKET, driven (45T)	1	AP
	39W-25446-00	SPROCKET, driven (46T)	1	AP
	39W-25450-00	SPROCKET, driven (50T)	1	AP
	39W-25452-00	SPROCKET, driven (52T)	1	AP
23	90109-08706	BOLT	6	

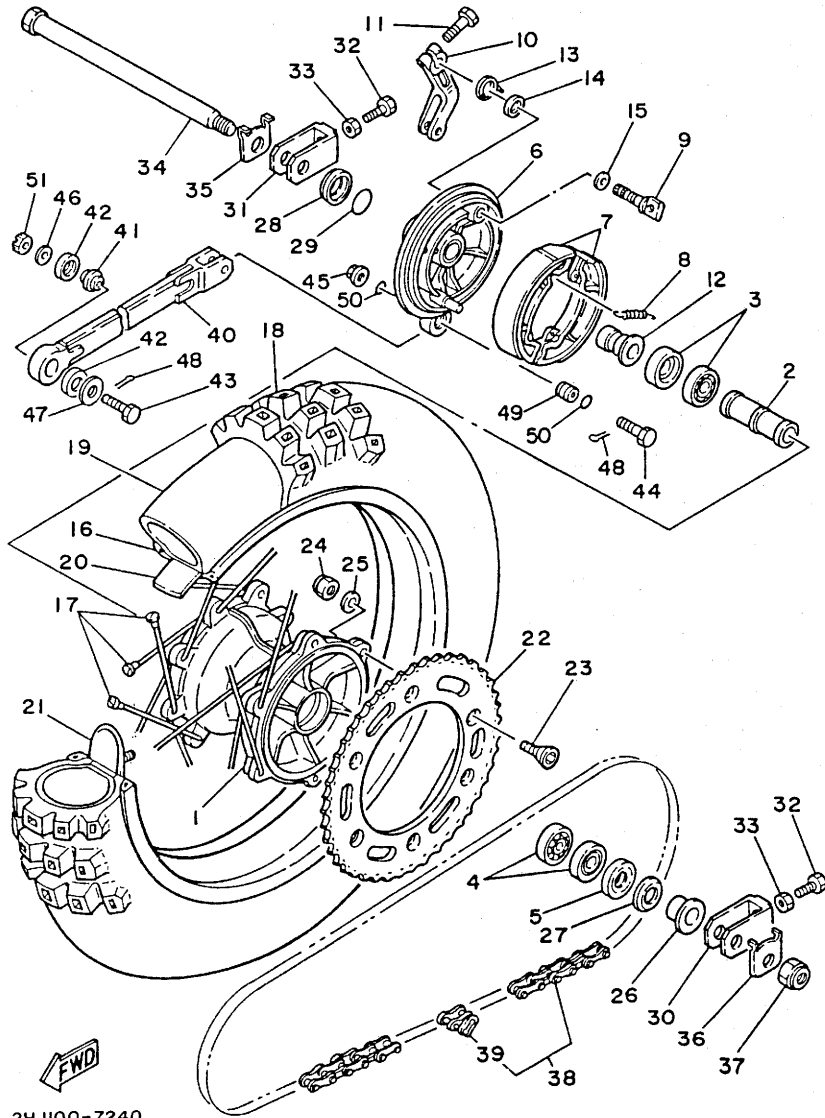

2HJ100-7240

D4

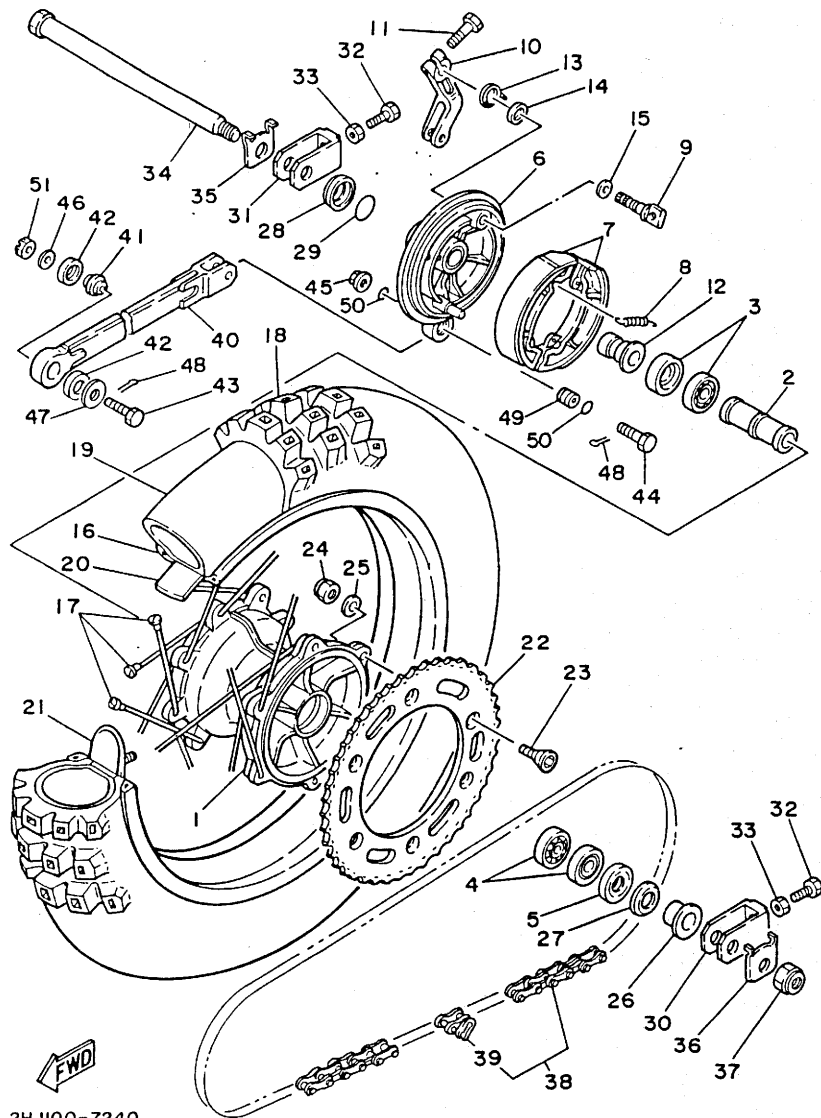

2HJ100-7240

FIG. 24 REAR WHEEL

REF. NO.	PART NO.	DESCRIPTION	Q'TY	REMARKS
24	95611-08100	NUT, u	6	
25	90201-081A6	WASHER, plate	6	
26	90387-200H2	COLLAR	1	
27	4V4-25367-00	COVER, hub dust	1	
28	23X-25327-00	COVER, plate	1	
29	93210-31114	O-RING	1	
30	56A-25388-01	PULLER, chain 1	1	
31	57H-25389-01	PULLER, chain 2	1	
32	90101-08475	BOLT	2	
33	95303-08700	NUT	2	
34	23X-25381-00	AXLE, wheel	1	
35	90209-21243	WASHER	1	
36	90209-18244	WASHER	1	
37	90185-18104	NUT, self-locking	1	
38	94585-20112	CHAIN, drive (DID520DS 112L)	1	
39	94685-20001	.JOINT, chain (D.I.D 520DS)	1	
40	23X-25371-00	BAR, tension	1	
41	93399-99910	BEARING	1	
42	93112-19006	OIL SEAL	2	
43	90102-08062	BOLT, with hole	1	
44	90109-08370	BOLT	1	
45	90185-08113	NUT, self-locking	1	
46	92901-08600	WASHER, plate	1	
47	90201-08107	WASHER, plate	1	
48	91401-20015	PIN, cotter	2	
49	90387-083F0	COLLAR	1	
50	93210-14167	O-RING	2	
51	95301-08900	NUT, slotted	1	

D5

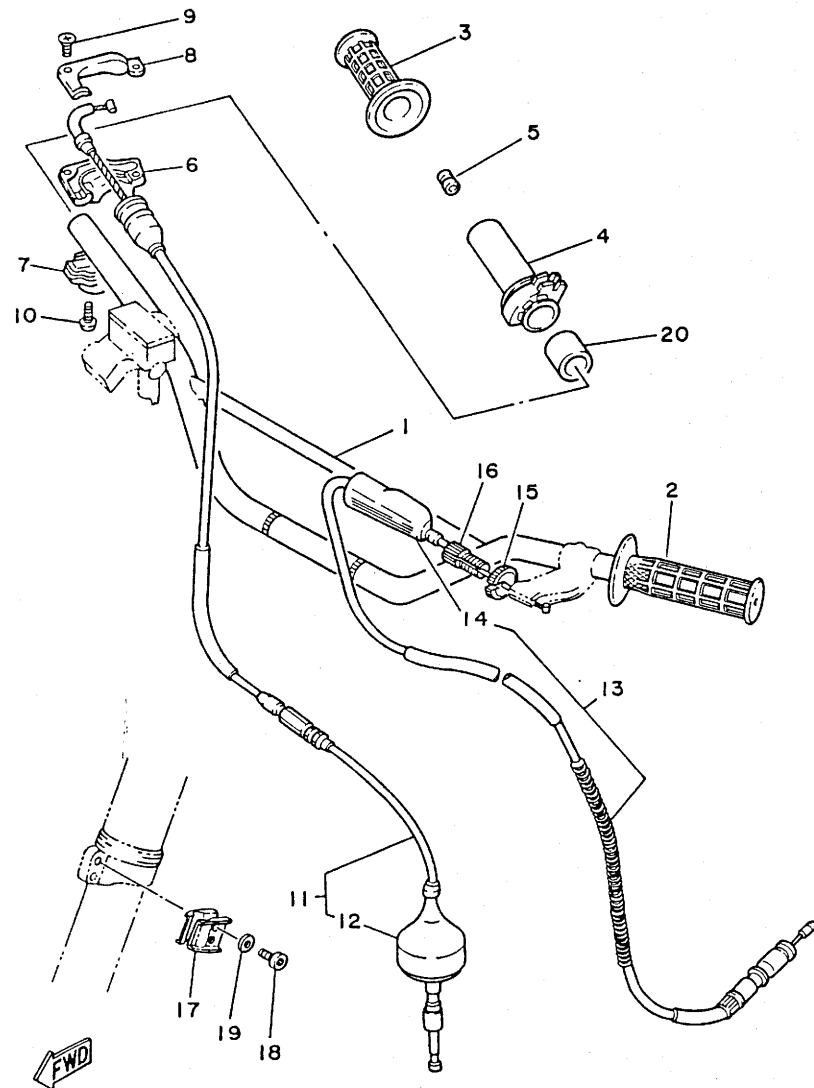

FIG. 25 STEERING HANDLE. CABLE

REF. NO.	PART NO.	DESCRIPTION	Q'TY	REMARKS
1	23X-26111-10	HANDLEBAR	1	
2	1LX-26241-01	GRIP (L.H)	1	
3	1LX-26242-01	GRIP (R.H)	1	
4	23X-26243-00	TUBE, throttle guide	1	
5	688-82535-00	GROMMET	1	
6	23X-26281-00	CAP, grip upper	1	
7	431-26282-01-98	CAP, grip lower	1	LOW GLOSS BLACK
8	5X2-2628H-01	CAP, wire	1	
9	98706-04012	SCREW, flat head	2	
10	98506-05016	SCREW, pan head	2	
11	40T-26311-00	CABLE, throttle 1	1	
12	510-26329-00	.CAP, rubber	1	
13	1LV-26335-00	CABLE, clutch	1	
14	382-26372-01	.COVER, handle lever 1	1	
15	90179-08401	NUT	1	
16	90123-08090	BOLT	1	
17	90465-16258	CLAMP	2	
18	91311-06016	BOLT	2	
19	92901-06600	WASHER, plate	2	
20	90560-22281	SPACER	1	

ILV100-6250

D6

FIG. 26 FRONT MASTER CYLINDER

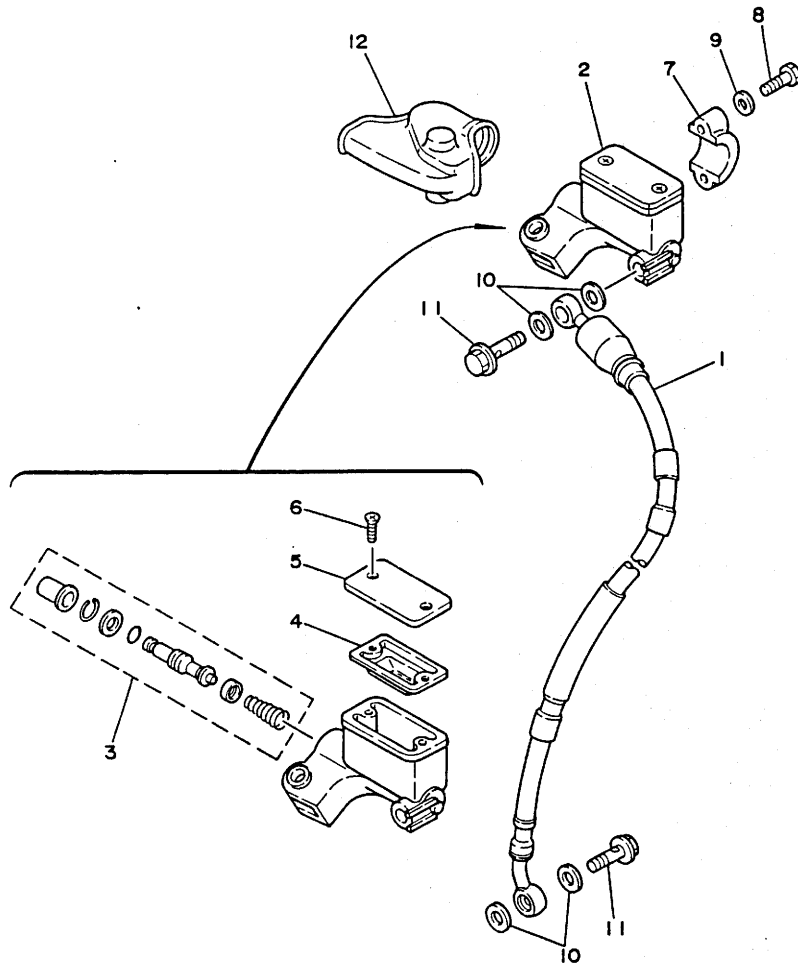

REF. NO.	PART NO.	DESCRIPTION	Q'TY	REMARKS
1	1RG-25872-10	HOSE, brake 1	1	
2	2HH-25850-00	MASTER CYLINDER ASSY	1	
3	56A-W0041-00	.CYLINDER KIT, master	1	
4	56A-25854-00	.DIAPHRAGM, reservoir	1	
5	56A-25852-00	.CAP, reservoir	1	
6	98706-04012	.SCREW, flat head	2	
7	56A-25867-00	BRACKET, master cylinder	1	
8	97326-06025	BOLT	2	
9	92906-06600	WASHER, plate	2	
10	90201-10118	WASHER, plate	4	
11	90401-10034	BOLT, union	2	
12	56A-26372-00	COVER, handle lever 1	1	



2HJ100-7260

D7

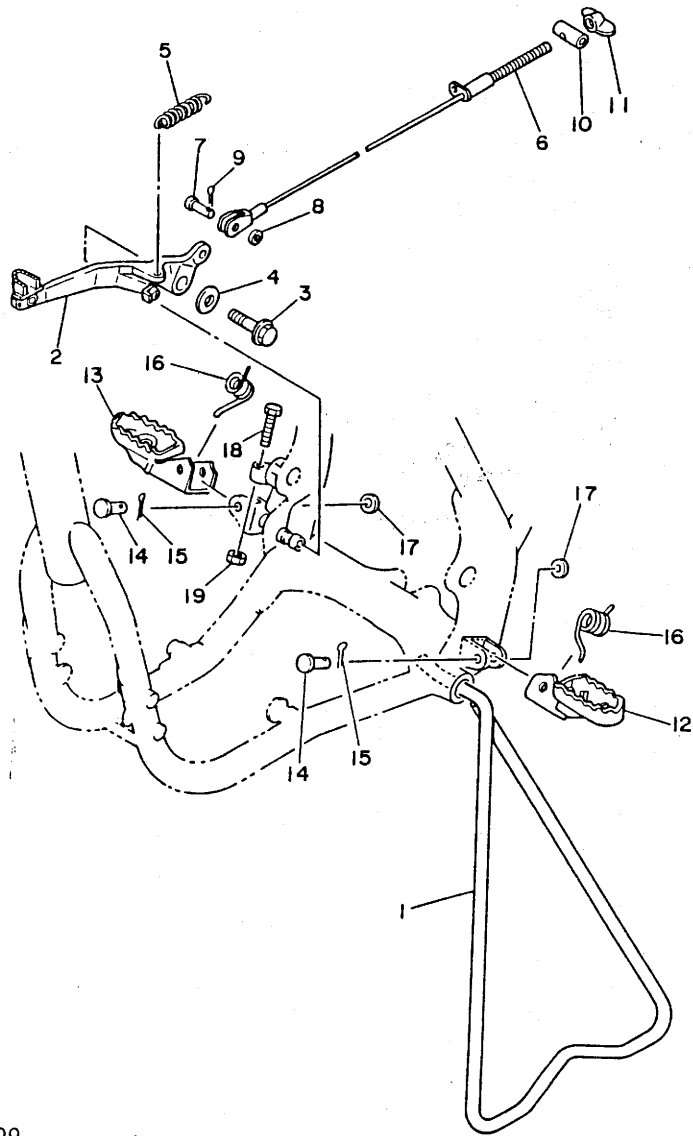

FIG. 27 STAND. FOOTREST

REF. NO.	PART NO.	DESCRIPTION	Q'TY	REMARKS
1	1LX-27311-00	STAND, side	1	
2	56A-27200-00	PEDAL, brake	1	
3	95023-08016	BOLT, flange	1	
4	90201-08730	WASHER, plate	1	
5	90506-16372	SPRING, tension	1	
6	40T-26351-00	CABLE, brake	1	
7	91790-08021	PIN, clevis	1	
8	90201-08544	WASHER, plate	1	
9	91401-25015	PIN, cotter	1	
10	90249-12008	PIN	1	
11	90175-06016	NUT, wing	1	
12	23X-27411-02	FOOTREST 1	1	
13	23X-27421-03	FOOTREST 2	1	
14	90240-10117	PIN, clevis	2	
15	91401-25015	PIN, cotter	2	
16	90508-20583	SPRING, torsion	2	
17	90201-10119	WASHER, plate	2	
18	97011-06020	BOLT	1	
19	95303-06700	NUT	1	



ILU010-6300

FIG. 28 GENERATOR

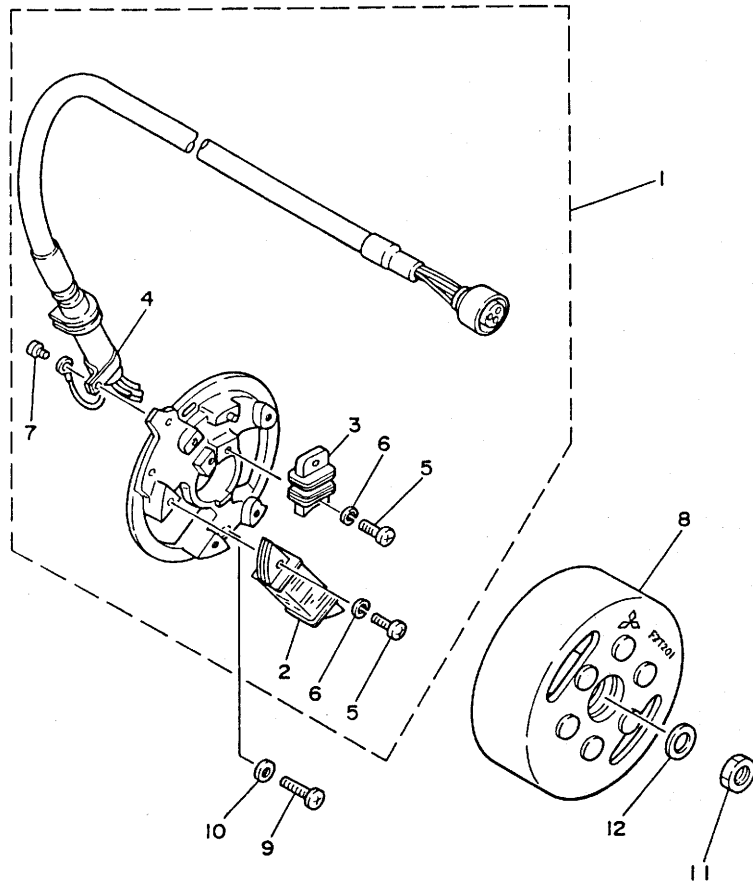

REF. NO.	PART NO.	DESCRIPTION	Q'TY	REMARKS
1	23X-85510-21	STATOR ASSY	1	
2	23X-85520-21	.COIL, charge	1	
3	23X-85580-20	.COIL, pulser	1	
4	104-81328-20	.CLAMP	1	
5	98511-04016	.SCREW, pan head	3	
6	92901-04100	.WASHER, spring	3	
7	110-81345-21	.SCREW, pan head	1	
8	23X-85550-20	ROTOR ASSY	1	
9	92501-06020	SCREW, pan head	2	
10	92901-06600	WASHER, plate	2	
11	90170-12067	NUT	1	
12	90201-12593	WASHER, plate	1	



57H110-5280

D9

FIG. 29 HANDLE SWITCH. LEVER

REF. NO.	PART NO.	DESCRIPTION	Q'TY	REMARKS
1	38V-82911-00	HOLDER, lever 1	1	
2	38V-82913-00	HOLDER, lever lower 1	1	
3	23X-83912-00	LEVER 1	1	
4	90109-06797	BOLT	1	
5	90201-082A9	WASHER, plate	1	
6	95606-06100	NUT, u	1	
7	98506-05018	SCREW, pan head	2	
8	92906-05100	WASHER, spring	2	
9	55Y-83922-00	LEVER 2	1	
10	90109-06577	BOLT	1	
11	95606-06100	NUT, u	1	
12	90149-06153	SCREW	1	
13	90170-06010	NUT	1	
14	90501-10312	SPRING, compression	1	
15	23X-83976-00	SWITCH, handle 1	1	
16	437-83936-00	BAND, switch cord	2	

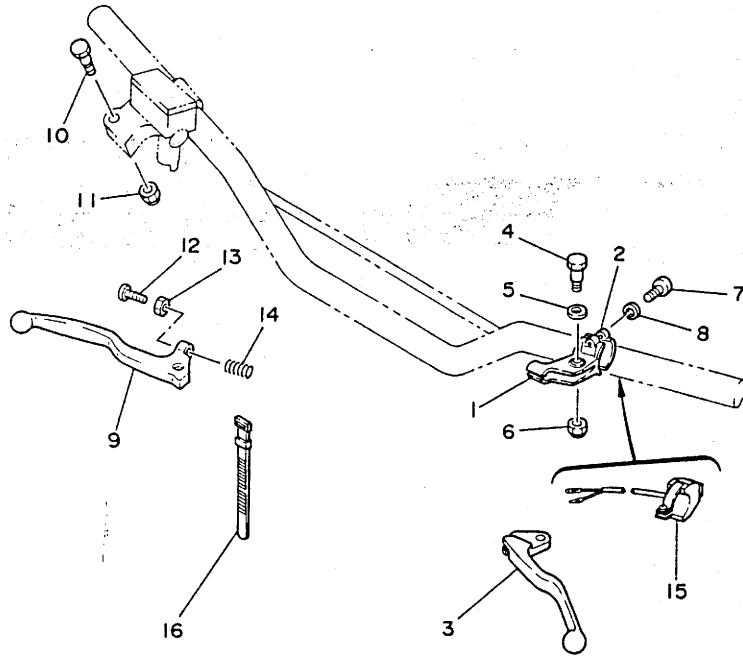

56A110-5320

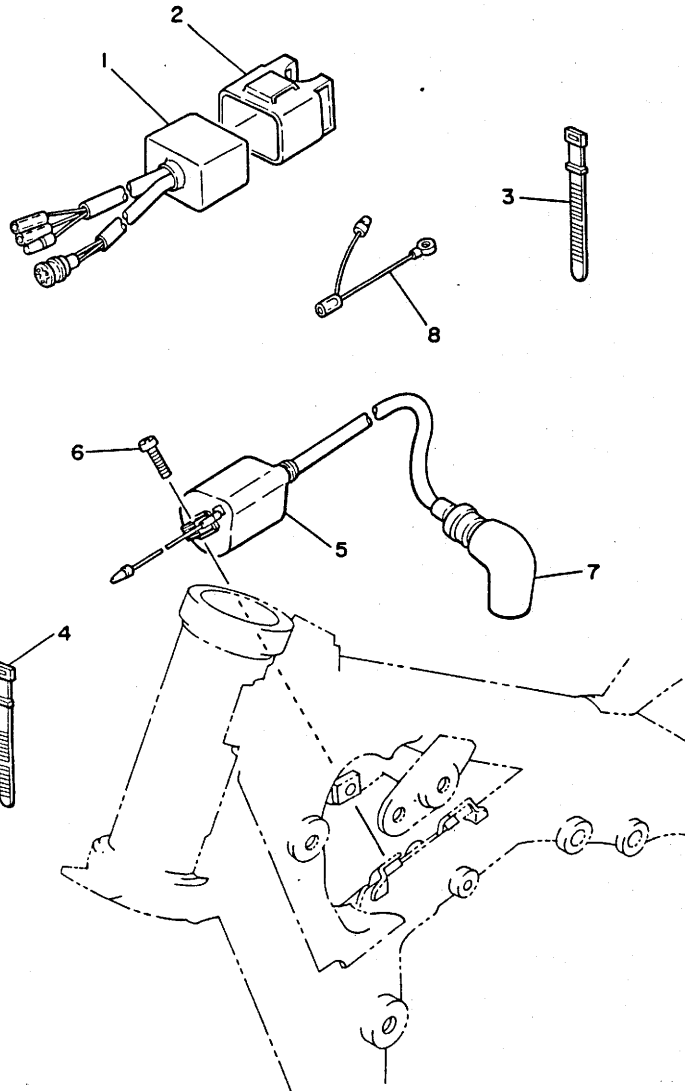

FIG. 30 ELECTRICAL 1

REF. NO.	PART NO.	DESCRIPTION	Q'TY	REMARKS
1	23X-85540-20	C.D.I. UNIT ASSY	1	
2	2A7-85546-00	BAND	1	
3	25G-83936-00	BAND, switch cord	2	
4	437-83936-10	BAND, switch cord	2	
5	43G-82310-40	IGNITION COIL ASSY	1	
6	92502-06016	SCREW, pan head	2	
7	3R0-82370-20	PLUG CAP ASSY	1	UR
	1M1-82370-21	PLUG CAP ASSY	1	UR WITH NOISE SUPPRESSOR
8	5X1-82519-01	WIRE, earth lead	1	



40T100-4280

D11

FIG. 31 ALTERNATE 1 (CHASSIS)

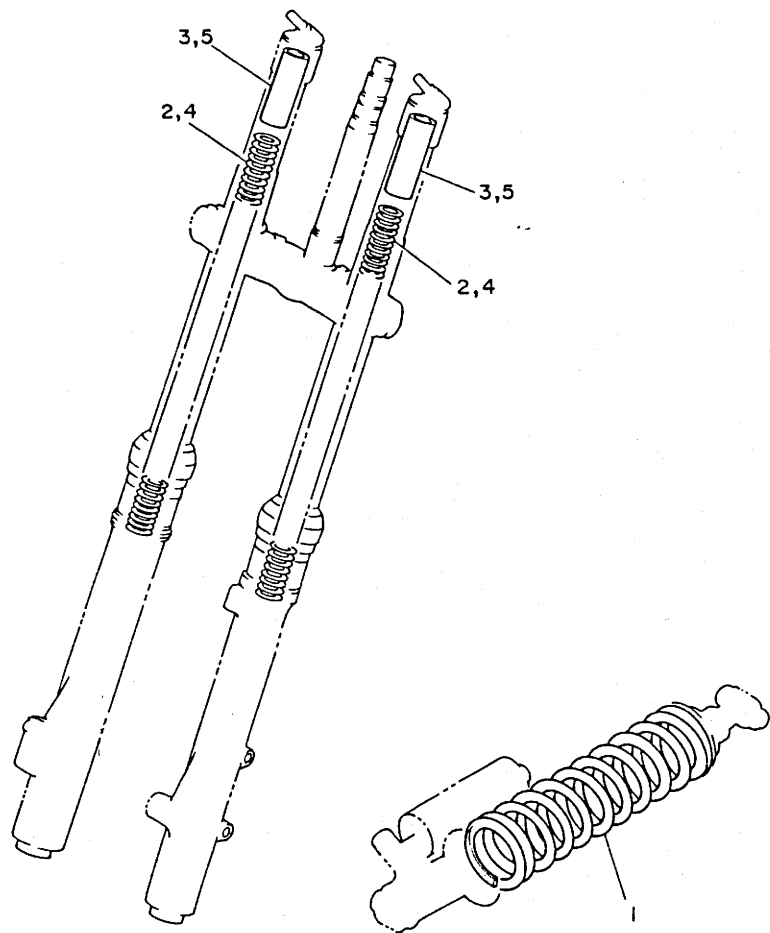

REF. NO.	PART NO.	DESCRIPTION	Q'TY	REMARKS
1	1LV-22212-10-6W	SPRING (K=5.25)	1	AP NATIVE RED (SOFT)
	1LV-22212-20-6W	SPRING (K=5.75)	1	AP NATIVE RED (HARD)
2	2HG-23141-L0	SPRING, front fork (K=0.35)	2	} (SOFT) WITH SET
3	1LV-23118-10	SPACER (L=90)	2	
4	2HH-23141-20	SPRING, front fork (K=0.40)	2	} (HARD) WITH SET
5	5X6-23118-L0	SPACER (L=50)	2	



2HH100-7340

D12

FIG. 32 REPAIR KIT

REF. NO.	PART NO.	DESCRIPTION	Q'TY	REMARKS
1	40T-11630-00	PISTON ASSY (STD)	1	AP
2	40T-11631-00-93	.PISTON (STD)	1	
3	5X6-11601-00	.PISTON RING SET (STD)	1	
4	275-11633-00	.PIN, piston	1	
5	93450-19052	.CIRCLIP	2	
6	40T-11630-10	PISTON ASSY (1ST O/S)	1	AP
7	40T-11635-00	.PISTON (0.25MM O/S)	1	
8	5X6-11601-10	.PISTON RING SET (1ST O/S)	1	
9	275-11633-00	.PIN, piston	1	
10	93450-19052	.CIRCLIP	2	
11	40T-11630-20	PISTON ASSY (2ND O/S)	1	AP
12	40T-11636-00	.PISTON (0.50MM O/S)	1	
13	5X6-11601-20	.PISTON RING SET (2ND O/S)	1	
14	275-11633-00	.PIN, piston	1	
15	93450-19052	.CIRCLIP	2	
16	40T-11630-30	PISTON ASSY (3RD O/S)	1	AP
17	40T-11637-00	.PISTON (0.75MM O/S)	1	
18	5X6-11601-30	.PISTON RING SET (3RD O/S)	1	
19	275-11633-00	.PIN, piston	1	
20	93450-19052	.CIRCLIP	2	
21	40T-11630-40	PISTON ASSY (4TH O/S)	1	AP
22	40T-11638-00	.PISTON (1.00MM O/S)	1	
23	5X6-11601-40	.PISTON RING SET (4TH O/S)	1	
24	275-11633-00	.PIN, piston	1	
25	93450-19052	.CIRCLIP	2	
26	3R5-11650-00	CONNECTING ROD ASSY	1	AP
27	3R5-11651-00	.ROD, connecting	1	
28	3R8-11681-00	.PIN, crank 1	1	

FIG. 32 REPAIR KIT

REF. NO.	PART NO.	DESCRIPTION	Q'TY	REMARKS
29	90209-25085	.WASHER	2	
30	93310-425N4	.BEARING, cylindrical	1	
31	93310-418E9	.BEARING, cylindrical	1	

NUMERICAL INDEX

PART NO.	GRID NO.	PART NO.	GRID NO.	PART NO.	GRID NO.	PART NO.	GRID NO.	PART NO.	GRID NO.	PART NO.	GRID NO.
56A-W0041-00	D- 7	3R5-11651-00	B- 3	2HH-14451-00	B- 4	3R5-16357-01	B-12	1LX-22151-00	C- 6	23X-23144-L0	C-10
2HH-W0045-00	D- 3		D-13	1LX-14452-00	C- 5	23X-16371-00	B-12	1LX-2217A-00	C- 6		C-11
56A-W0047-00	D- 3	3R8-11681-00	B- 3	39X-14452-00	C- 5	1LV-16380-00	B-12	1LX-2217F-00	C- 7	23X-23145-L0	C-10
51L-W0048-00	D- 3		D-13	2HJ-14453-00	B- 4	1LV-17121-00	B-13	1LX-2217G-00	C- 7		C-11
56A-W0057-00	D- 3	137-13115-00	B- 9	39K-14457-00	B- 4	1LV-17131-01	B-13	2HH-22178-00	C- 3	4V4-23146-L0	C-10
1LU-W1441-00	B- 4	2HJ-13565-00	B- 4	2HH-14458-00	B- 4	1LV-17141-00	B-13	2HH-2218A-00	C- 7		C-11
3R5-W1511-01	B- 9	26A-13575-00	B- 4	56A-14459-00	B- 4	1LV-17151-00	B-13	39W-22199-01	C- 6	3J2-23147-00	C-10
40T-W2536-00	D- 4	40T-13581-00	B- 4	39X-14462-00	B- 4	1LV-17211-00	B-13	2HH-22201-00	C- 8		C-11
40T-11111-00	B- 2	1LV-13584-00	B- 4	2HH-14468-00	B- 4	1LV-17221-00	B-13	2HJ-22210-00-6W	C- 8	2HH-23151-L0	C-10
40T-11181-00	B- 2	56A-13610-01	B- 4	1LU-14477-00	B- 4	1LV-17231-00	B-13	23X-22211-00	C- 8		C-11
2HJ-11311-00	B- 2	56A-13613-00	B- 4	2HJ-14610-00	B- 8	1LV-17241-00	B-13	1LV-22212-00-6W	C- 8	4V4-23153-L0	C-10
1LV-11351-00	B- 2	56A-13616-00	B- 4	2HJ-14613-00	B- 8	1LV-17251-00	B-13	1LV-22212-10-6W	D-12		C-11
40T-11400-00	B- 3	39X-13621-00	B- 4	40T-14619-01	B- 2	1LV-17411-00	B-13	1LV-22212-20-6W	D-12	4V4-23157-L0	C-10
3R5-11412-00	B- 3	57H-1410A-00	B- 7	2HJ-1469A-00	B- 8	5X5-17421-00	B-13	5X6-22214-00	C- 8		C-11
3R5-11422-00	B- 3	2HJ-14101-00	B- 6	1LX-14744-00	B- 8	23X-17461-30	B-13	1LX-22223-00	C- 8	2HH-23158-L0	C-10
5X6-11601-00	B- 3	40T-14103-00	B- 7	39X-14747-00	B- 8	3Y1-17461-40	B-13	1LX-22225-00	C- 8		C-11
	D-13	23X-14104-00	B- 7	2HJ-14753-00	B- 8	3Y1-17461-50	B-14	39W-22417-00	C- 8	2HH-2316A-L0	C-10
	B- 3	40T-14106-00	B- 6	40T-14771-00	B- 8	23X-18101-00	C- 2	483-22419-01	C- 8		C-11
5X6-11601-10	D-13	23X-14107-35	B- 6	565-14771-00	B- 8	23X-18110-01	C- 2	1LV-22463-00	C- 8	1LX-23167-L0	C-11
	B- 3	40T-14112-25	B- 6	2HJ-1490J-00	B- 6	3R4-18140-00	B-15	2HH-23102-L0	C-10	2HH-23170-L0	C-10
	D-13	40T-14112-30	B- 6	3R4-15113-00	B- 9	5X5-18511-00	B-15	2HH-23103-L0	C-10		C-11
5X6-11601-30	B- 3	40T-14112-35	B- 6	4V4-15118-00	B- 9	3R5-18512-00	B-15	1LX-23108-00	C-12	4V4-23171-L0	C-10
	D-13	40T-14115-00	B- 6	3R5-15121-05	B- 9	5X5-18513-00	B-15	2HH-23110-L0	C-10		C-11
5X6-11601-40	B- 3	278-14117-00	B- 6	1G8-15362-00	B-10	5X5-18531-01	B-15		C-11	2HH-23173-L0	C-10
	D-13	8H0-14131-00	B- 7	56A-15378-00	B-10	5X5-18535-01	B-15	43M-23111-L0	C-10		C-11
40T-11630-00	D-13	8A7-14141-54	B- 6	23X-15381-00	B- 9	24Y-18540-00	B-15		C-11	2HH-2318R-00	C-10
40T-11630-10	D-13	8A7-14141-56	B- 6	56A-15383-00	B- 9	2HJ-21110-00-UJ	C- 3	1LV-23118-10	D-12		C-11
40T-11630-20	D-13	8A7-14141-58	B- 6	40T-15411-00	B-10	1HX-2135F-00	C- 7	2HH-23118-L0	C-10	4V4-23188-L0	C-10
40T-11630-30	D-13	193-14142-35	B- 6	23X-15421-00	B-10	43R-2137W-00	C- 5		C-11		C-11
40T-11630-40	D-13	193-14142-40	B- 6	40T-15431-00	B-10	40T-2141K-00	C- 3	5X6-23118-L0	D-12	34K-23190-00	C- 9
40T-11631-00-93	B- 3	193-14142-45	B- 6	1LV-15451-00	B-10	40T-2141L-00	C- 3	4H7-23119-00	C-10	23X-23190-L0	C-10
	D-13	137-14143-90	B- 6	3R4-15462-00	B-10	40T-21415-00	C- 3		C-11		C-11
40T-11631-00-94	B- 3	137-14143-92	B- 6	23X-15618-00	B-11	40T-21416-00	C- 3	55Y-2312G-M0	C-10	43M-23191-L0	C-12
275-11633-00	B- 3	137-14143-94	B- 6	40T-15620-01	B-11	1LV-21425-00	C- 3		C-11	43M-23192-L0	C-12
	D-13	137-14143-96	B- 6	23X-15621-01	B-11	1LV-21426-00	C- 3	4V4-23125-L0	C-10	2HH-23340-L0	C-12
	D-13	137-14143-98	B- 6	23X-15641-00	B-11	5X6-21511-10	C- 4		C-11	3R4-23389-00	C- 9
	D-13	313-14146-00	B- 7	23X-15651-00	B-11	1LX-21611-00	C- 4	2HH-23126-L0	C-10	5Y3-23393-00	C-11
	D-13	40T-14146-00	B- 6	57H-15661-00	B-11	50W-21631-00	B-15	122-23129-00	C-10	1LX-23395-00	C- 9
	D-13	3R3-14153-00	B- 6	40T-15664-00	B-11	39X-21642-00	C- 4		C-11	1W1-23416-00	C- 9
40T-11635-00	B- 3	40T-14158-00	B- 7	23X-16111-00	B-12	1LX-21711-01-98	C- 5	2HH-23136-L0	C-11	40T-23435-00-98	C- 9
	D-13	57H-14175-00	B- 7	39X-16150-00	B-12	1LX-21721-00	C- 5	2HG-23141-L0	D-12	1E6-23441-00	C- 9
40T-11636-00	B- 3	363-14184-00	B- 6	2K7-16154-00	B-12	2HH-2173L-00	C- 5	2HH-23141-L0	C-10	1E6-23442-00	C- 9
	D-13	214-14185-00	B- 6		B-12	2HH-2174L-00	C- 5		C-11	5X6-23485-11	C- 9
40T-11637-00	B- 3	537-14186-00	B- 6	2K7-16181-00	B-12	1LV-22110-01	C- 6	2HH-23141-20	D-12	43M-23489-L0	C-12
	D-13	40T-14187-00	B- 6	5X5-16321-00	B-12	307-22123-00	C- 9	4V4-23142-L0	C-10	1LV-24110-00	C-13
40T-11638-00	B- 3	2HH-14197-00	B- 7	4H7-16325-00	B-12	156-22127-00	C- 6		C-11	40T-2412F-00	C-14
	D-13	2K7-14197-00	B- 7	23X-16351-00	B-12	3R4-22129-00	C- 6	1LX-23144-L0	C-10	24X-24144-00	C-13
3R5-11650-00	D-13	4V3-1441K-00	B- 4	23X-16356-00	B-12	1LX-22141-00	C- 6		C-11	5X6-2415F-01	C-13

NUMERICAL INDEX

PART NO.	GRID NO.	PART NO.	GRID NO.	PART NO.	GRID NO.	PART NO.	GRID NO.	PART NO.	GRID NO.	PART NO.	GRID NO.
59V-24173-00	C-13	56A-25867-00	D- 7	23X-85580-20	D- 9	90185-08113	C- 3	90202-14077	C- 9	90467-10008	C-13
1LX-24181-00	C-13	1RG-25872-10	D- 7	90101-06291	D- 4		D- 5	90209-18244	D- 5	90467-23059	B- 4
22W-24181-00	C- 5	5R2-25917-00	D- 3	90101-08475	D- 5	90185-10037	C- 9	90209-20213	B-13	90468-26177	B-11
	C- 5	56A-25919-00	D- 3	90101-14648	C- 6	90185-10120	C- 8	90209-21243	D- 5	90480-18354	C-13
23X-24184-00	C-13	56A-25919-10	D- 3	90102-08062	D- 5		C- 8	90209-22082	B-13	90501-10312	D-10
2HJ-24254-00	C-14	56A-25926-00	D- 3	90105-06138	C- 4	90185-14096	C- 7		B-13	90501-13720	B-11
1LX-24500-00	C-13	56A-25937-00	D- 3	90105-08091	C- 9	90185-14112	C- 7	90209-25085	B- 3	90501-24408	B-12
4X8-24512-00	C-13	23X-26111-10	D- 6	90105-08107	C- 3	90185-16127	C- 6		D-14	90504-03033	B- 4
4X8-24534-00	C-13	1LX-26241-01	D- 6	90105-08214	C- 3	90185-18104	D- 5	90215-20212	B-12	90506-16372	D- 8
5X7-24611-01	C-13	1LX-26242-01	D- 6	90105-08449	C- 3	90185-18126	B-12	90215-21239	B-14	90507-20002	D- 4
5X7-24612-00	C-13	23X-26243-00	D- 6	90109-06551	B- 8	90201-06067	C- 6	90240-10117	D- 8	90507-20030	B- 8
509-24724-00	C-15	5X2-2628H-01	D- 6	90109-06577	D-10	90201-06070	C-13	90249-12008	D- 8	90508-14423	B-12
1LX-24731-00	C-15	23X-26281-00	D- 6	90109-06757	D- 3	90201-061E8	C- 5	90280-03045	B- 3	90508-20583	D- 8
1LX-24738-01	C-15	431-26282-01-98	D- 6	90109-06797	D-10	90201-06571	C- 4	90282-07019	B-12	90508-26421	B-15
107-24741-00	C-15	40T-26311-00	D- 6	90109-08370	D- 5		C- 5	90338-07011	B- 9	90508-29361	C- 2
2HJ-24741-00	C- 5	510-26329-00	D- 6	90109-08573	B- 8		C- 5	90340-12095	B- 9	90508-29641	D- 4
5X6-24748-10	C-15	1LV-26335-00	D- 6	90109-08706	D- 4		C- 9	90380-16158	C- 6	90508-30422	B-11
1LX-24770-00	C-15	40T-26351-00	D- 8	90109-10700	C- 8	90201-081A6	C- 3	90381-16060	C- 6	90560-12171	C- 2
1LX-25104-00	D- 2	382-26372-01	D- 6	90109-10704	C- 8		D- 5	90387-06387	C-13	90560-15240	D- 2
2HH-25111-00-98	D- 2	56A-26372-00	D- 7	90116-08394	B- 2	90201-08107	D- 5	90387-06681	C- 4	90560-20226	D- 4
322-25118-00	D- 2	23X-26393-00	B- 9	90116-12315	B- 2	90201-082A9	D-10	90387-081A3	B- 8	90560-22281	D- 6
55U-25181-00	D- 2	56A-27200-00	D- 8	90116-12316	B- 2	90201-08544	D- 8	90387-083F0	D- 5	91311-06016	D- 6
57H-25304-00	D- 4	1LX-27311-00	D- 8	90119-06056	B- 5	90201-08612	B- 8	90387-086N4	C- 3	91316-06020	B- 4
57H-25311-00-98	D- 4	23X-27411-02	D- 8	90119-06063	C- 4	90201-08649	B- 2	90387-121E8	C- 9	91316-06025	B-10
40T-25321-00-98	D- 4	23X-27421-03	D- 8	90119-06081	B- 4	90201-08730	B- 8	90387-126H8	C- 8	91316-06045	B- 9
23X-25327-00	D- 5	1LV-28100-00	C- 3	90119-06117	C- 4		D- 8	90387-127G8	C- 8	91316-06050	B- 9
40T-25351-00	D- 4	2X4-2811A-00	C- 3	90122-06025	B- 4	90201-100A1	C- 9	90387-156R7	D- 2	91316-06060	B- 9
148-25353-00	D- 4	104-81328-20	D- 9	90123-08090	D- 6	90201-100E9	C- 8	90387-157L9	D- 2	91316-06075	B- 9
5X6-25355-00	D- 4	110-81345-21	D- 9	90123-14104	C- 7	90201-100F7	C- 8	90387-160H4	B- 9	91401-20015	D- 5
4V4-25367-00	D- 5	43G-82310-40	D-11	90149-06011	C-13	90201-101J1	C- 3		B- 9	91401-20020	C- 9
23X-25371-00	D- 5	1M1-82370-21	D-11	90149-06153	D-10	90201-101I8	D- 7	90387-164N1	C- 7	91401-25015	D- 8
23X-25381-00	D- 5	3R0-82370-20	D-11	90149-06179	B-12	90201-101I9	D- 8	90387-164N2	C- 6		D- 8
56A-25388-01	D- 5	5X1-82519-01	D-11	90152-06010	B-11	90201-106F2	C- 6	90387-164N3	C- 6	91790-08021	D- 8
57H-25389-01	D- 5	688-82535-00	D- 6	90159-06016	B-12	90201-120E6	C- 8		C- 7	91810-17016	B- 2
2J5-25394-01	D- 2	38V-82911-00	D-10	90170-06010	D-10	90201-123E8	C- 9	90387-200H1	D- 4	92501-06010	B- 8
2X5-25394-00	D- 4	38V-82913-00	D-10	90170-12067	D- 9	90201-12593	D- 9	90387-200H2	D- 5		B- 9
39W-25444-00	D- 4	23X-83912-00	D-10	90170-20255	B-12	90201-14740	C- 7	90387-25663	B-13		C-13
39W-25445-00	D- 4	55Y-83922-00	D-10	90175-06016	D- 8	90201-164H4	C- 6	90401-10034	D- 7	92501-06012	B- 9
39W-25446-00	D- 4	25G-83936-00	D-11	90179-08401	D- 6		C- 7	90402-10005	C- 6		B- 9
39W-25448-00	D- 4	437-83936-00	C- 4	90179-10280	C- 3	90201-17327	B-12	90430-06016	B-10		C- 9
39W-25450-00	D- 4		D-10	90179-12244	B-11	90201-17545	B-11	90430-12038	B- 9		C-14
39W-25452-00	D- 4	437-83936-10	D-11	90179-20255	B-14	90201-186H3	B-12	90445-08605	B- 9		C-15
2HH-25810-00	D- 3	23X-83976-00	D-10	90179-22330	C- 9	90201-20278	B-13	90445-09100	C-13	92501-06014	C-13
1LX-25831-00	D- 3	23X-85510-21	D- 9	90179-25033	C- 9	90201-20358	B-11	90445-112E9	C-13		C- 5
34X-25845-00	D- 3	23X-85520-21	D- 9	90185-08106	C- 3	90201-253K0	B-13	90460-56257	B- 4	92501-06020	D- 9
2HH-25850-00	D- 7	23X-85540-20	D-11		C- 6		B-13	90460-74254	B- 4	92502-06016	D-11
56A-25852-00	D- 7	2A7-85546-00	D-11	90185-08113	C- 3	90202-06010	C-13	90465-06247	B-10	92506-06008	B-10
56A-25854-00	D- 7	23X-85550-20	D- 9		C- 3	90202-08022	C- 3	90465-16258	D- 6	92506-06016	C- 5

NUMERICAL INDEX

PART NO.	GRID NO.	PART NO.	GRID NO.	PART NO.	GRID NO.	PART NO.	GRID NO.	PART NO.	GRID NO.	PART NO.	GRID NO.
92506-06016	C- 5	93210-08483	C- 8	94212-18188	D- 4	98706-04012	D- 7				
92506-06025	B-10	93210-14104	B-10	94227-21123	D- 2	98980-06020	C-13				
92506-06035	B-10	93210-14167	D- 5	94307-21145	D- 2	99009-17400	B-11				
92701-06012	B- 9	93210-19501	B-11	94309-18146	D- 4	99510-12016	B- 9				
92901-04100	D- 9	93210-31114	D- 5	94416-21435	D- 2						
92901-05100	B- 6	93210-65752	B- 8	94425-18415	D- 4						
92901-06600	B- 8	93300-20501	B-13	94585-20112	D- 5						
	C-13		B-13	94685-20001	D- 5						
	C-13	93300-60816	C- 3	95021-08045	C- 3						
	C-14	93306-00406	D- 4	95023-08016	C-15						
	C-15	93306-00418	D- 4		D- 8						
	D- 6	93306-20107	B-15	95301-08600	B- 2						
	D- 9	93306-20209	D- 2	95301-08900	D- 5						
92901-08200	C- 5	93306-30615	B- 3	95303-06600	B-12						
	C- 6		B- 3	95303-06700	D- 8						
92901-08600	D- 5	93310-418E9	B- 3	95303-08700	D- 5						
92901-10200	C- 3		D-14	95601-05100	B- 4						
92906-05100	D-10	93310-425N4	B- 3	95606-06100	D-10						
92906-06100	B-10		D-14		D-10						
92906-06600	B-10	93311-62035	B-13	95611-08100	D- 5						
	B-10		B-13	95701-08500	C-12						
	C- 5	93315-21721	B-12	95701-12100	B- 2						
	D- 7	93315-22045	C- 7	95801-06012	C-15						
92990-03100	B- 4	93315-22046	C- 6	95802-08045	C- 6						
92990-06100	B- 8	93317-32231	C- 6	95811-08045	D- 3						
	B- 8	93332-00008	C- 9	95811-08055	C- 3						
	B-12	93332-00023	C- 9	95811-10016	C- 6						
	C- 5	93342-22208	C- 6	95811-10065	C- 3						
	C-12	93399-99910	D- 5	95821-08025	B- 8						
	C-13	93399-99916	C- 8	95821-08035	C- 9						
	C-13	93410-20038	B-13	95821-08055	C-12						
	C-13	93440-25084	B-13	97011-06020	D- 8						
92990-08100	B- 8		B-13	97311-06025	C- 2						
93102-12106	C- 2	93440-30113	C- 8	97313-06016	B- 8						
93102-17263	B-12	93450-19052	B- 3		C-13						
93102-20281	D- 2		D-13	97313-06035	C-13						
93102-20309	B-11		D-13	97313-08016	B- 8						
93102-32M07	B-13		D-13	97326-06025	D- 7						
93103-30150	B- 3		D-13	97801-03008	C-13						
93103-40091	B- 3		D-13	98001-06020	C- 6						
93104-18077	C- 8	93450-28063	C- 7	98501-04006	C- 8						
93106-22019	C- 6		C- 7	98501-05016	B- 6						
93106-28023	D- 4	93501-04011	B-11	98506-04018	C-12						
93108-35004	C- 6	93515-32029	B-12	98506-05016	D- 6						
93109-14021	D- 4	93606-14154	B-15	98506-05018	D-10						
93109-20029	C- 6	93608-25150	C- 2	98511-04016	D- 9						
	C- 7	94108-215N7	D- 2	98580-03008	B- 4						
93112-19006	D- 5	94112-186N1	D- 4	98706-04012	D- 6						